

# Annual Report 2012



CENTRE FOR  
ENVIRONMENT-  
FRIENDLY ENERGY  
RESEARCH

BIGCCS Centre - International CCS Research Centre



**CONTENTS**

1. Message from the Chairman of the Board .....	3
2. Message from the Centre Director .....	4
3. Summary 2012 .....	5
4. Vision and Goals .....	6
5. Research Plan and Strategies .....	8
6. Organization .....	9
6.1 Organizational Structure .....	9
6.2 Partners .....	11
6.3 Cooperation between Partners .....	13
7. Results from Research Activities .....	14
7.1 Expanded Activities Level .....	14
7.2 CO <sub>2</sub> Capture – Sub-Project 1 .....	16
7.3 CO <sub>2</sub> Transport – Sub-Project 2 .....	20
7.4 CO <sub>2</sub> Storage – Sub-Project 3 .....	22
7.5 CO <sub>2</sub> Value Chain – Sub-Project 4 .....	26
7.6 Academia - Sub-Project 5 .....	27
7.7 Deliverables .....	28
8. International Cooperation .....	29
9. Recruitment .....	30
10. Communication and Dissemination .....	31
11. Innovation and Centre Building .....	33
12. Health, Safety and Environment .....	34
12.1 Specific Activities in 2012 .....	34
12.2 Accidents, Incidents, etc. ....	35
 ATTACHMENTS .....	 36
A1 Personnel .....	37
A2 Accounting Report .....	42
A3 Publications .....	43
 CONTACT INFORMATION.....	 50

**Front page:** *The MTS uniaxial loading frame, in the Formation Physics laboratory, set up for measuring indirect tensile strength of shales during thermal expansion.*

**Photo:** *Thor Nielsen*

## **1. MESSAGE FROM THE CHAIRMAN OF THE BOARD**

We are already there, midway in the first period of the BIGCCS Centre. We have just been put under scrutiny by an international expert panel to see how BIGCCS fares. The process leading up to this review was challenging for the centre – by the mere size of BIGCCS and its operations and proved to be a very useful exercise for us. We counted publications, reports, presentations, spin-offs and PhD and Post doc assignments and achievements. I was impressed by the quality and volume of what the Centre has been achieving and we clearly see the tracks of BIGCCS leading to innovation projects inside and outside the Centre. And this is a key criterion for the CEER scheme. The board is keen to see the results being pursued in products and processes and for the second part of the first period of BIGCCS we will establish a vehicle for this by inviting more vendors to the consortium and thus ensure broad industrial uptake of results from the Centre. This will be done in full understanding with all the partners and will prepare the ground for a second period of BIGCCS. There are no signs of CCS being dismissed as something we can do without and we have no intentions of lagging behind in scientific excellence in CCS and to underpin deployment of CCS in Europe.

At present Europe is living in a sense of denial for CCS. This is however not the case for competing economies like China, USA, Canada and Australia. Looking behind the horizon of 2020 it is clear that we will need CCS. Because we do not have the resources to do renewables to the full extent, because fossil fuels are wonderful if we can use them without causing climate change havoc and we simply cannot do without for the locked-in carbon and for industrial processes. In essence, the future holds no place for fossil fuels without technologies to take care of the wrapping fossil fuels come with – CO<sub>2</sub>. So it is time to change from discussing this as a bridging technology to a long term technology.

Last year I referenced the 2 ppm CO<sub>2</sub> we add every year to the atmosphere. The implications of this are often ignored. Adding something means that the concentration is increasing every year and even if we manage to reduce the emissions we will still add CO<sub>2</sub> to the atmosphere. It is like blowing into a balloon. This is also where CCS can help, using co-firing of biomass means that we can actually tuck away CO<sub>2</sub> and thus go carbon negative.

So where does all this leave us? In my view it is about "carpe diem"- grab the chance now. And this goes for all stakeholders in the Centre. Time has never been more favourable than now for investing in CCS R&D, innovation and technology deployment. Luck favours those who are prepared it is said, BIGCCS is all about preparing for the wave of technology needs for reducing our CO<sub>2</sub> footprint. Such a vision is truly inspiring for the excellent work being performed by the Centre and our partners.



*Chairman of the Board  
Nils A. Røkke  
(Photo: Gry Kari Stimo)*

## **2. MESSAGE FROM THE CENTRE DIRECTOR**

Dear BIGCCS friends! In 2012 we prepared the mid-way evaluation, and summing up the first four years of operation it is clear that the centre has the strengths required to continue operation, also after the period of eight years.

2012 was the year when BIGCCS contributed with six oral presentation and 19 posters at GHGT-11 and our member of the BIGCCS Scientific Committee, Sally Benson (Stanford University) got *the Greenman Award*. The BIGCCS Centre has during the period 2009-2012 produced 156 conference papers, 52 journal publications with referee, and 108 confidential reports and memos. The centre management and members are participating in the EU EERA network on CCS, the ZEP platform, and the ECCSEL networks. During the same period BIGCCS R&D partners have been involved in 40 EU-funded CCS projects (SINTEF/NTNU: 15, BGS: 13, and GEUS: 12). The number of PhD and Postdocs funded by BIGCCS is now 25 of which three have completed their projects. The total turnover is increased from NOK 40 million in 2009 to NOK 70 million in 2012.

In 2012 another two KPN projects were amended to the BIGCCS Consortium Agreement (CAMPS and FEFROCK) and two new KPN project were funded by Climit (BIGCLC phase III and HyMemCOPI). In 2012 the Gassnova projects BIGH2 Phase 2, OxyGT, SOLVit, CO<sub>2</sub> Fieldlab and PdCORE were operating, proving the innovation potential of the BIGCCS research. Finally, the EU FP7 project *IMPACTS - The impact of the quality of CO<sub>2</sub> on transport and storage behaviour* was granted. Also, Gassnova, BIGCCS and SUCCESS initiated a pre-project to speed up the introduction of large-scale CO<sub>2</sub> storage; *Large Scale Storage of CO<sub>2</sub> on the Norwegian Shelf*. Further, in 2012 BIGCCS contributed to the ECCSEL initiative *ECCSEL Norway CCS RI – Phase 1 – the Norwegian node of ECCSEL RI* applying for 75 million NOK for CCS research infrastructure. The proposal will be evaluated and decided on by the Research Council in 2013. All this shows that the BIGCCS Center is a vehicle for innovation and value creation within our partners organizations as well as for other stake holders in CCS.

Now BIGCCS is preparing for TCCS-7 taking place in Trondheim 4-6 June, and 260 abstracts were received. Along with the conference, meeting and side-events will take place. See you then!

We are also awaiting the decision to be made by the IEA Greenhouse Gas R&D programme whether BIGCCS under the auspices of NTNU and SINETF will be the organizer of the GHGT-13 Conference in 2016.

By this I would like to thank our partners in BIGCCS; from industry, always contributing to relevance, improved quality and higher ambitions, from research; for delivering excellent work. Thank you all for the willingness to contribute to large-scale implementation of CCS. I would also like to thank the Centre Management Group for inspiring cooperation during 2012. Last, but not least thanks to the Task leaders and the researchers who again have shown an amazing capability regarding delivering according to plan.



Centre Director, Mona J. Mølnevik  
(Photo: Gry Kari Stimo)

### **3. SUMMARY 2012**

The vision of BIGCCS Centre is to contribute to the ambitious targets in the *Climate Agreement* adopted by the Norwegian Parliament in February, 2008. The main objective is to develop knowledge and technology to enable sustainable power generation from fossil fuels based on cost-effective CO<sub>2</sub> capture, safe transport, and underground storage of CO<sub>2</sub>. The research topics covered by the Centre require in-depth studies of fundamental aspects related to capture, transport, and storage. In-depth research relies on a dual research methodology for which both laboratory experiments and mathematical modelling are employed. The Centre has a special focus on enhancing exploitation of results, innovation, and value creation.

BIGCCS is set up with a General Assembly, a Board, a Scientific Committee (SC), an Exploitation and Innovation Advisory Committee (EIAC), and a Centre Management Group (CMG). Technical committees are established for the different Sub-projects. The Centre has 21 partners; 9 industrial, nine from research, and three universities. Partners come from different parts of the industry value chain, and represent both multinational and leading Norwegian companies. Cooperation takes place in specified project, tasks, and in joint meetings.

BIGCCS has through its **research activities** produced 121 deliverables and 102 publications during 2012. Two new competence building projects have been granted for inclusion in the BIGCCS project portfolio, one on membranes and one on chemical looping. In addition, infrastructure funding worth NOK 7 million has been secured for construction of test rigs for chemical looping and NOK 4 million has been allocated from already available funding to the CO<sub>2</sub> mixture characterization test rig.

By 2012, the "**Academia**" sub-program has recruited 25 researchers – 19 PhD and six Post-Doc candidates. Females make up 28 percent, and candidates come from 10 different countries. One PhD candidate and two Post.docs have completed their projects.

**International cooperation** is expanded through the inclusion of new projects in the Centre. New associated partners are: North Carolina State University, RWTH Aachen University, Georgia Tech, North Carolina State University, Brigham Young University, National Renewable Energy Laboratory, and Stanford University.

In terms of **communication and dissemination**, preparations have been made for the organization of the 7<sup>th</sup> Trondheim CCS Conference in 2103, and a bid has been made to host the GHGT-13 Conference in 2016. In November, 2012, BIGCCS was strongly present at the GHGT-11 Conference with a joint exhibition booth with NORDICCS, and six oral and 19 poster presentations. The Centre produced 102 publications in 2012, up 57% from 2011. The total number of BIGCCS publications is now 222.

**Innovation** activities in 2012 has focused on three different axes; activating the Exploitation and Innovation Advisory Committee, development of spin-off projects, and preparations for establishment of a new body under BIGCCS with the working title "BIGCCS Innovation". The idea is to spur innovation activities by establishing a separate body under BIGCCS with a narrow focus on innovation possibilities. New members will be invited, especially vendors, which can contribute in pinpointing concrete innovation possibilities, as well as participate in the development of new technologies and products.

Systematic **HSE** activities have been continued with specific emphasis on safe operation of testing activities in laboratories. The area of HSE in fieldwork has been identified as a focus area for 2013. Two incidents were reported in 2012 – one dangerous condition and one near accident. Neither has resulted in personnel injury.

## **4. VISION AND GOALS**

### VISION

The vision of the BIGCCS Centre is to contribute to the ambitious targets in the Climate Agreement adopted by the Norwegian Parliament in February, 2008.

### OVERALL OBJECTIVE

The BIGCCS Centre will enable sustainable power generation from fossil fuels based on cost-effective CO<sub>2</sub> capture, safe transport, and underground storage of CO<sub>2</sub>. This will be achieved by building expertise and closing critical knowledge gaps in the CO<sub>2</sub> chain, and by developing novel technologies in an extensive collaborative research effort.

### TANGIBLE OBJECTIVE

To pave the ground for fossil fuel based power generation that employ CO<sub>2</sub> capture, transport and storage with the potential of fulfilling the following targets:

- 90 % CO<sub>2</sub> capture rate
- 50 % cost reduction
- fuel-to-electricity penalty less than six percentage points compared to state-of-the-art fossil fuel power generation

### SCIENTIFIC OBJECTIVE

To provide crucial knowledge and a basis for technology breakthroughs required to accelerate the development and deployment of large-scale CCS enhanced by comprehensive international co-operation. The fulfilment of this objective relies on long-term, targeted basic research of high scientific quality, professional management, and international user/partner involvement.

### TECHNOLOGICAL OBJECTIVE

To foster future innovation and value creation within CCS technologies along the whole CO<sub>2</sub> value chain. To create the basis for new services and products for the user partners originating from the centre activities ranging from novel separation technologies to value creation from transport and storage on the Norwegian Continental Shelf.

### RECRUITMENT OBJECTIVE

To recruit and educate personnel, of which 50% are women, with first-class competence within CCS-related topics (18 PhDs, eight Post-docs, 50 MSc graduates) to ensure recruitment both to industry and research institutions.

### SPECIFIC OBJECTIVES

The following specific scientific objectives have been defined for the BIGCCS Centre:

#### **Capture and systems:**

Explore novel techniques for pre-combustion, post-combustion and oxy-fuel CO<sub>2</sub> capture, including both new and retrofit technologies contributing to cost reductions focusing on increased efficiency in CO<sub>2</sub> separation by:

- Development of high-temperature membranes and sorbents, and precipitating solvent systems characterised by improved capacity, minimum degradation and a benign environmental impact.
- Continuation the development efforts in the pre-combustion and oxy-fuel combustion area for key enabling technologies. Contribute to cost reductions through increased gas turbine efficiency and thus plant efficiency.
- Assessments of advanced CO<sub>2</sub> capture techniques to the benefit of other energy intensive industries and offshore applications.
- Enhancement innovation and value creation by evaluating the realisation potential of novel CO<sub>2</sub> capture technologies and identify the main challenges to be faced when integrating these with industrial processes and point out directions for further research related to the CO<sub>2</sub> capture technology development.

**Transport:**

Develop a coupled fluid-material fracture assessment model to enable safe and cost-effective design and operation of CO<sub>2</sub> pipelines by improving the fundamental understanding of the interaction between the mechanical and fluid dynamical behaviour.

Furthermore, it is an objective to acquire accurate experimental data on thermophysical properties of CO<sub>2</sub>-rich mixtures at conditions relevant for operations involved in CCS chains, primarily conditioning and transport. The data will be used to improve and/or extend the range of validity of existing thermodynamic models.

**Storage:**

Development of in-depth knowledge enabling long-term and safe storage of CO<sub>2</sub> by:

- Qualification and management of CO<sub>2</sub> storage recourses by generating fundamental knowledge through interpretation of geological data from wells, geophysical data and understanding of basin history.
- Developing the understanding and description of interactions of CO<sub>2</sub> with the storage volumes to give the scientific basis required for establishing safe geological CO<sub>2</sub> storage.
- Improving CO<sub>2</sub> storage safety by combining geophysical monitoring methods with reservoir fluid flow simulations to reduce the uncertainties of time-lapse geophysical measurements. Improve detection and quantification of possible CO<sub>2</sub> leakage rates from geological storage, and describe preventive and corrective actions to handle potential leakages.

## 5. RESEARCH PLAN AND STRATEGIES

### RESEARCH APPROACH

The research topics covered by the BIGCCS Centre require in-depth studies of fundamental aspects related to CO<sub>2</sub> capture, CO<sub>2</sub> transport, and CO<sub>2</sub> storage. Research relies on a dual methodology for which both laboratory experiments and mathematical modelling are employed. The modelling and experimental activities share the same theory or hypotheses, and seek answers to the same questions from different points of view. There is a two-way coupling between the modelling and experimental work: Experiments are necessary for developing and verifying models. At the same time, developing and understanding models will lead to an improved understanding of the described phenomena.

In BIGCCS, research takes place within international networks of scientists, including the participation of world-class experts. The emphasis is on building expertise through quality research at a high international level, both within the research tasks, the post-doctoral work, and through the education of PhDs. New knowledge is in part gained through an integrated assessment where the realisation potential of novel CO<sub>2</sub> capture technologies is revealed when these are integrated with industrial processes, supporting the development of research strategies for the Centre. In CO<sub>2</sub> transport, the combination of theories and models describing pipeline fracture resistance and CO<sub>2</sub> fluid dynamics requires a coupled analysis of the problem using different numerical simulation methods that will create improved understanding of the two-way influence between the CO<sub>2</sub> fluid and the pipeline. In CO<sub>2</sub> storage, the basic knowledge of CO<sub>2</sub> behaviour in the reservoir and rock mechanics when influenced by CO<sub>2</sub> will be used in aggregated reservoir and basin models.

### METHODS FOR INNOVATION

The BIGCCS Centre is developed with special focus on enhancing exploitation, innovation and value creation. Since innovation has often proved to occur in the interface between disciplines, and is an area of research itself, the Centre has a separate activity lead by Studio Apertura (NTNU Social Research). The responsibility of Studio Apertura is to develop and follow up an innovation assessment process to ensure that the attention in the BIGCCS Centre research tasks is also on the potential commercial value of technology. The research tasks are organised to increase interaction between disciplines and expert groups.

Creative workshops, the Consortium Day, and the Exploration and Innovation Advisory Committee stimulate innovation. The three phases of the Centre period, of which the first two end with an evaluation and recommendation for the next phase, will direct the Centre towards fields of promising research and ideas. Overall, the research-based transfer of knowledge and technology will enhance the potential for innovation and value creation, hence this emphasis on innovative technologies with a potential for enabling CCS ensures that the concept of *additionality* is fulfilled.<sup>1</sup>

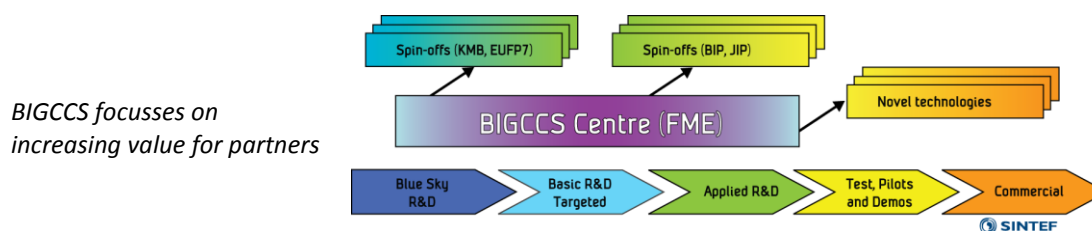

<sup>1</sup> *Additionality as described in Kyoto's Clean Development Mechanism, i.e. the measure would not have been realised without the incentive provided for it by the mechanism*



## 6. ORGANIZATION

The BIGCCS Consortium is made up of highly ranked research institutes and universities, and strong industry partners that include international oil and gas companies, energy companies, process industry, engineering companies, and CCS technology vendors. All the partners in the BIGCCS Centre are major players within CCS, and will have extensive CCS activity also outside of the Centre. By strengthening the competence building and technological development through industry involvement, the BIGCCS Consortium is built to secure the premises for innovation and value creation.

### 6.1 ORGANIZATIONAL STRUCTURE

#### GOVERNANCE STRUCTURE

The BIGCCS Centre is organised along topically oriented research areas. In order to manage this large interdisciplinary research centre, a management framework is set up to ensure autonomy, information exchange, governance, and clearly defined responsibilities. The governance structure is shown in the figure below.

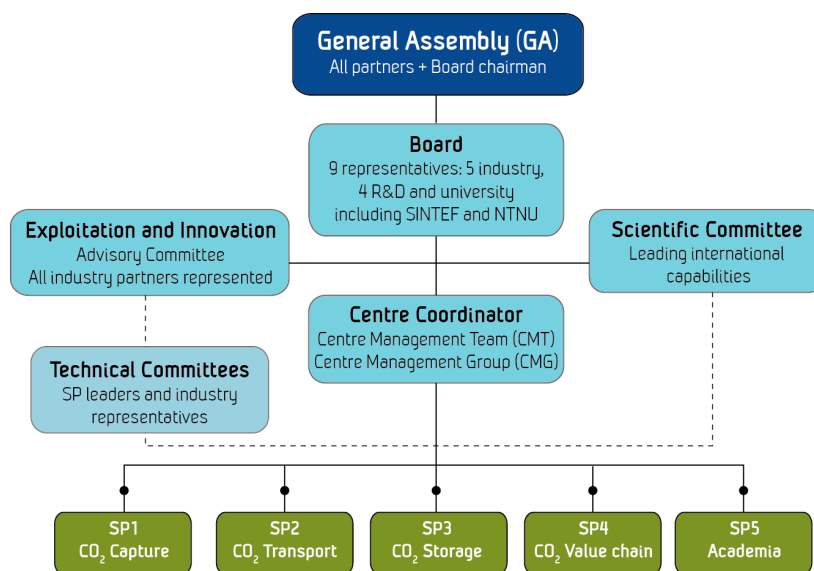

*BIGCCS governance structure*

- **Sub-project (SP) Leaders:** coordinating the research tasks of the sub-projects.
- **Task Leaders:** preparing plans and executing the research in accordance with budgets and deliverables defined in approved task plans and within the Centre contracts.
- **Scientific Committee (SC):** advisory committee with leading international academic capabilities giving guidance to the Centre towards the scientific progress.
- **Exploitation and Innovation Advisory Committee (EIAC):** includes all user partners of the Centre, evaluating the commercial potentials of evolving technology and identify opportunities for spin-off projects.
- **Technical Committee(s):** advisory committees established for specific research topics to ensure knowledge transfer between Centre partners and will include representatives both from R&D providers and industry.
- **Centre Management Team (CMT):** responsible for the day-to-day operations.
- **Centre Management Group (CMG):** includes CMT and the SP leaders, responsible for carrying out the operations of the Centre.

- **Board:** operative decision-making body of the Centre.
- **General Assembly (GA):** ultimate decision-making body, ensuring that operations are carried out in accordance with the Consortium Agreement.

EXPLOITATION AND INNOVATION ADVISORY COMMITTEE

The *Exploitation and Innovation Advisory Committee* (EIAC), was established in December 2011, and will be an important advisory tool for BIGCCS in spurring innovation activities. The committee is open for participation from all industrial partners, and so far four of them have volunteered to join. EIAC delivered its first report to the Board in 2012.

SCIENTIFIC COMMITTEE

The BIGCCS Scientific Committee (SC) was established in 2010, and held its meeting in 2012 in conjunction with the GHGT-11 in Kyoto, Japan. At this meeting the Committee made an assessment of the scientific quality and achievements of BIGCCS, and reported back to the Board via the Centre Director. The report constituted a very useful feedback to the Centre. In general terms the committee focussed on issues such as: clarity in motivation and state-of-the-art, ambitions in terms of goals and objectives, relevance of the research, how the research fits into the global scientific landscape, and communication of results. Chair of the Committee is Professor May-Britt Hägg (NTNU, Norway).

WORK BREAKDOWN STRUCTURE

The work breakdown structure is shown in the figure below.

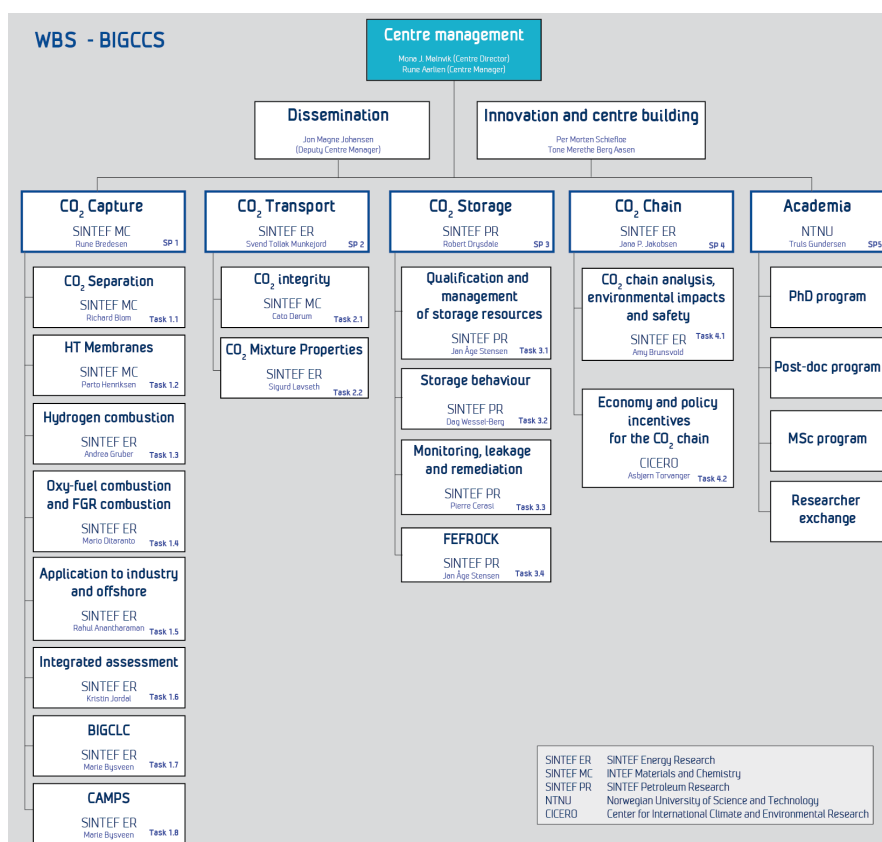

*BIGCCS work structure breakdown. Task 1.8 and 3.4, are two KPN projects that formally became a part of BIGCCS in 2012.*

The BIGCCS Centre is built as a matrix organisation, where all activities supporting the ambition of the Centre will be coordinated, evaluated, and reported. The Centre management conducts centre-specific strategic activities for releasing the full potential of the Centre:

- **Centre building and distributive work processes:** The objectives are to clarify expectations, to facilitate development of the overall plans for the Centre, and to facilitate distributed work processes. In particular, the tasks *Integrated Assessment* and *CO<sub>2</sub> Chain* rely on close collaboration with the other tasks. Another aim is to establish arenas for building personal relations and knowledge exchange to release the added value of the Centre, e.g., annual Consortium Days, technical meetings and active use of the BIGCCS Intranet for sharing information.
- **Promoting innovation:** Actions are to raise the consciousness of the partners pertaining to the identification of opportunities for innovation and to facilitate creative workshops where research challenges are combined with the complementary comprehensions of the Center partners in order to release the potential for overcoming scientific hurdles. Assessments of research results from the sub-projects are also presented as a basis for the expert panel of industry representatives to evaluate the commercial potential of evolving technologies.
- **Synthesis of Centre results:** The Centre management coordinates a collaborative task for synthesis of Centre results measured against the scientific and technological objectives. By the end of the proposed Centre period, this task will provide recommendations on paths for potential innovation and value creation as well as for future R&D within CCS. A public version will be made available and will serve as a major deliverable from the Centre. The task will also conduct a scientific review of all Centre activities and prepare decision basis for the Board to consolidate activities and budgets before Phase II and III of the BIGCCS Centre.

## 6.2 PARTNERS

The following organizations have been partners in the BIGCCS Centre during 2012:

### INDUSTRY PARTIES:

- **Aker Solutions:** Leading global provider of engineering and construction, technology products, execution, service and integrated solutions within oil and gas and process industry.
- **ConocoPhillips Scandinavia:** Oil and gas company. Involved in several CCS R&D projects. Involved in CO<sub>2</sub> Capture Project (CCP2), U.S. DOE Regional Partnerships, EU programs: CO2ReMoVe, Cachet, CO2Net, and an Australian effort called CO2CRC
- **Det Norske Veritas:** Risk assessment related to CCS, involved in several R&D projects within CCS.
- **Gassco:** Operator of natural gas transport and processing systems, responsible for development of CO<sub>2</sub> transport concepts at Kårstø and Mongstad, CO<sub>2</sub> capture from industrial applications.
- **GDF Suez (joined 2010):** Europe's largest gas purchaser and the world's fifth largest power producing company. GDF Suez has four key sectors: liquefied natural gas, energy efficiency services, independent power production and environmental services. Employs 214,000 people.
- **Hydro:** Hydro is a supplier of aluminium and aluminium products. Based in Norway, the company employs 23,000 people in 40 countries and has activities on all continents.
- **Shell Technology Norway:** Oil and gas company. Involved in several R&D projects on CCS, such as Dynamis and DECARBit. Industrial partner in Test Centre Mongstad.
- **Statoil:** Oil and gas company. Involved in several CCS R&D projects. Experience in CO<sub>2</sub> transport and storage (Sleipner, Snøhvit, In Salah), building a CO<sub>2</sub> capture plant at Mongstad.
- **TOTAL E&P:** Involved in several R&D projects within CCS and the Lacq CCS Regional Pilot. Partner in Snøhvit and Sleipner.

RESEARCH INSTITUTES:

- **British Geological Survey (BGS):** World leader in science and geophysical research into the structure of underground reservoirs for CO<sub>2</sub>. Work committed in SP3 CO<sub>2</sub> storage.
- **CICERO:** Global climate change, international climate policy, key policy institute for climate change.
- **Deutsches Zentrum für Luft und Raumfahrt (DLR):** Advanced measurement techniques for combustion, large scale high-pressure combustion facilities, expertise on detailed kinetic chemistry.
- **Geological Survey of Denmark and Greenland (GEUS):** Pioneer in CO<sub>2</sub> storage options, co-ordinator of the EU FP6 Geocapacity, works in opportunities for CO<sub>2</sub> storage in Europe, work committed in SP3 CO<sub>2</sub> storage.
- **Norges Geologiske Undersøkelse (NGU):** Government agency, bedrock, mineral resources, surficial deposits and groundwater.
- **NTNU Social Research:** Organisation and management structure development. Work processes and innovation. Studio Apertura is involved in the Centre building and innovation processes.
- **SINTEF Energy Research (Host Institution):** Thermo and fluid dynamics, combustion, modelling, and integration. Project coordination and management. Major European R&D provider within CCS.
- **SINTEF Petroleum Research:** Petroleum and reservoir technology, geo sciences. Modelling of possible escape from stored CO<sub>2</sub>, long- and short-term behaviour of CO<sub>2</sub> in the geological environment.
- **SINTEF - SINTEF Materials and Chemistry:** Thermo-chemical conversion, process simulation and optimization; chemistry; materials synthesis, characterization and development.

UNIVERSITIES:

- **Norwegian University of Science and Technology (NTNU):** Thermo-chemical conversion, chemistry, unit and process modelling and integration, petroleum and reservoir technology, geo sciences.
- **TU München (TUM):** Combustion – experiments and modelling – specialised in reactive flows, transport phenomena and thermo-acoustics. Cooperation with Alstom, highest ranked “research university” in Germany.
- **University of Oslo (UiO):** Thermo-chemical conversion, chemistry.

ASSOCIATED PARTNERS

- **Ruhr Universität Bochum:** Cooperation on fundamental properties of CO<sub>2</sub> (Task 2.2)
- **Sandia National Laboratories:** Combustion (Task 1.3, 1.4, and 1.8)
- **University of Berkeley:** Combustion (Task 1.3 and 1.4)
- **North Carolina State University:** (Task 1.2 and Task 1.8)
- **RWTH Aachen University:** (Task 1.2)
- **Georgia Tech:** (Task 1.8)
- **Brigham Young University:** (Task 1.8)
- **National Renewable Energy Laboratory:** (Task 1.8)
- **Stanford University:** (Task 1.8)

### 6.3 COOPERATION BETWEEN PARTNERS

#### TASKS

Cooperation between the research and industry partners takes place at the task level. Task leaders coordinate activities and organize separate meetings between the relevant partners. During 2012, teleconference and video meetings have been increasingly used in order to limit time-consuming travelling, and this has proven to be a popular and effective solution for the partners. Technical meetings took place in May and December with more than 50 participants.

#### SUB-PROJECTS

Sub-Project leaders coordinate the efforts of the different Tasks. At least two joint meetings are held annually for all sub-project leaders (*CMG seminar*) with focus on developing research strategies and on organizational issues. In 2012, such meetings were held both with and without industrial partners. Sub-projects also organize an annual *Sub-Project Day* where all tasks and partners are represented.

#### CONSORTIUM DAY

The Centre organizes an annual *Consortium Day*. At this event all partners and researchers are invited, and the intention is to provide a snapshot of last years' activities and results. The 2012 Consortium Day was held at Rica Nidelven in Trondheim, Norway, on September 19 and drew approximately 60 attendees. The day after, a *PhD seminar* was held where the current BIGCCS PhD students presented progress of their work for the consortium partners. The seminar gathered roughly 35 participants.

#### CENTRE MANAGEMENT GROUP

The *Centre Management Group* (CMG) consists of the SP leaders, leaders for the centre building and dissemination activities, the Centre Director and the Centre Manager. Representatives from SINTEF Energy Research, SINTEF Petroleum Research, SINTEF Materials and Chemistry, as well as NTNU Social Research are present. The CMG held 22 meetings during 2012, including one full-day *CMG seminar*. The focus of the CMG is to ensure that the annual work programme is carried out according to plan, and to oversee the day-to day operations.

#### TASK LEADER SEMINAR

A *Task Leader Seminar* is organized at least once every year. The intention is to bring together all Task Leaders to discuss topics of general interest to the Centre as such. This year the seminar was held at Lerkendal Stadium on September 13, and the full-day event was used to discuss how to improve "External communication in BIGCCS".

## 7. RESULTS FROM RESEARCH ACTIVITIES

### 7.1 EXPANDED ACTIVITIES LEVEL

The diagram below shows that the annual turnover for BIGCCS has increased from below NOK 40 million in 2009 to more than NOK 70 million in 2012. The expansion is by and large caused by the four extra KPN projects and additional infrastructure funding.

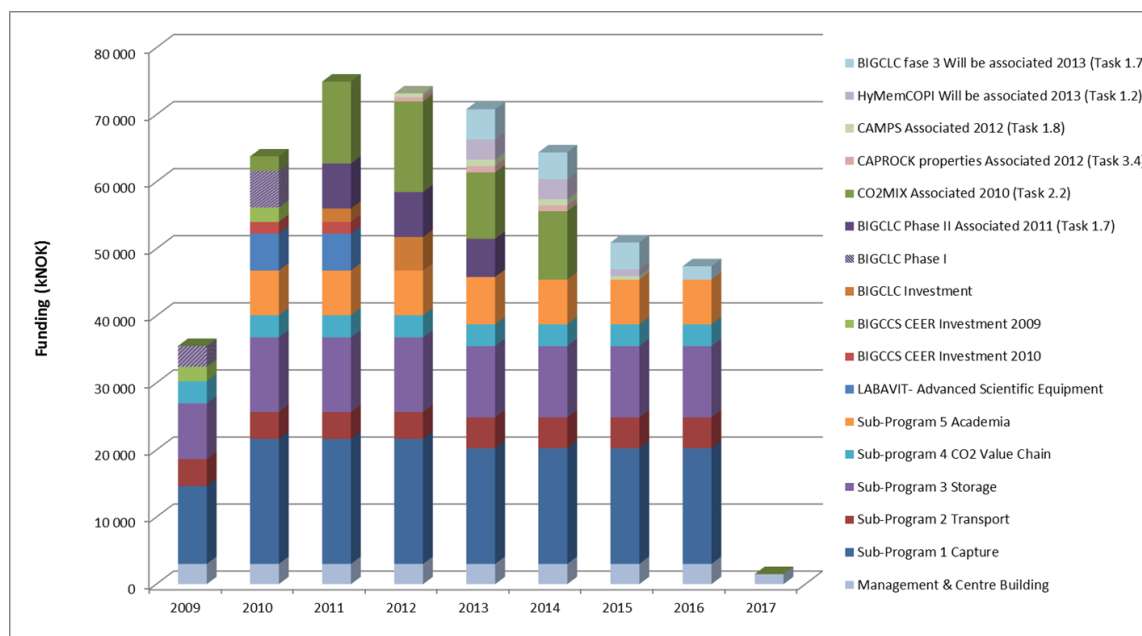

BIGCCS annual turnover as of January 1, 2013

During 2012, the BIGCCS activity level continued to increase. Below are listed the major additions.

#### NEW ACTIVITIES

Two KPN proposals were granted by the RCN in December, 2011, and were formally included in BIGCCS during 2012 - Task 1.8, *Cross-Atlantic Combustion Modelling, Programming and Simulation (CAMPS)*, and Task 3.4, *Fundamental Effects of CO<sub>2</sub> on Rock Properties (FEFROCK)*.

Four KPN project proposals were submitted to the RCN with a support letter from the BIGCCS Centre during the autumn of 2012. The project proposals were subject to thorough discussions in the BIGCCS CMG. The CMG saw the potential addition of these projects to BIGCCS, as a strategically important and valuable supplement to already on-going activities. The RCN decided in 2012 to fund two of the submitted proposals, namely; *Novel hybrid membranes for post combustion CO<sub>2</sub> capture in power plant and industry (HyMemCOPI)* and *BIGCLC Phase III*.

#### NEW INFRASTRUCTURE

**Chemical Looping Combustion** – In autumn 2011, BIGCCS received NOK 7.0 million from the RCN for investments in a 150 kW CLC test rig. This rig will allow BIGCCS to become a leading actor within the field of CLC. The rig consists of an innovative double-loop design made of two circulating fluidized bed (CFB) reactors interconnected by divided loop-seals and a bottom extraction (lifter). Chosen solutions are based on industrial standards where the size is large in comparison with laboratory units. This makes further scale-up easier. The rig is equipped with provisions for long-term and continuous operation, which is

needed in order to push CLC technology further. Finally, the rig will be a valuable tool to test and validate new oxygen carrier particles under realistic conditions. Design of the rig began in 2011 and construction was done during 2012. Leakage tests and component and signal testing were done early 2013, and first particle circulation tests were done in March 2013 using inert particles (olivine) and at temperatures just above room temperature. The rig is built as one complete skid at the main supplier site south in Norway and will be transported to Trondheim during spring 2013.



*Left illustration: Planned layout of the CLC test rig  
Right photo: The CLC test rig from the top and down (Source: SINTEF)*

**CO<sub>2</sub> Mixture Properties** – A test rig for measurements of phase equilibrium of CO<sub>2</sub> mixtures was installed in the laboratories of SINTEF Energy Research in 2012. The purpose of the rig is to enable prediction of phase behavior of fluids relevant for relevant CCS fluids under CCS transport. The rig has a total budget of NOK 4.3 million, of which NOK 4 million was allocated from BIGCCS investment funds. Phase equilibrium measurements will start during spring 2013.



*Phase equilibrium cell under pre-acceptance test (Source: SINTEF)*

## 7.2 CO<sub>2</sub> CAPTURE – SP1

SP1 consists of the following eight tasks:

- Task 1.1: CO<sub>2</sub> separation
- Task 1.2: High temperature membranes
- Task 1.3: Hydrogen combustion
- Task 1.4: Oxy-fuel combustion and flue gas recirculation combustion
- Task 1.5: Application to industry and offshore
- Task 1.6: Integrated assessment
- Task 1.7: Chemical looping combustion
- Task 1.8: CAMPS

### TASK 1.1 – CO<sub>2</sub> SEPARATION

WP 1.1.1 "Absorption and absorption systems" consists of two main subtasks, i) Precipitating systems for CO<sub>2</sub> capture and ii) Dynamic modeling and analysis of absorption based systems. Precipitating systems based on selected amino acid salts has been characterized by Vapor-Liquid-Solid Equilibrium (VLSE) and heat of absorption measurements, and a simplified VLSE model has been implemented. For dynamic modeling and analysis of absorption-based systems the main focus has been dynamic modeling of process units (flash and heat exchanger) and development of a numerical methodology for dynamic process flow sheet simulations. In WP 1.1.2 "High temperature sorbents for CO<sub>2</sub> capture", lifetime of natural mineral dolomite for use in high temperature CO<sub>2</sub> capture processes (600-900°C) has been improved by chemical modification while keeping the working capacity at a satisfactory level. In cooperation with Task 1.6 the stability and cyclic capacity needed to make post combustion carbonate looping feasible have been evaluated.

### TASK 1.2 – HIGH TEMPERATURE MEMBRANES

The work has focused on high temperature Oxygen Transport Membranes (OTM) suitable for separating oxygen from air for oxy-combustion or pre-combustion processes. OTMs based on La<sub>2</sub>NiO<sub>4</sub> material are successfully fabricated and tested for over 200 hours at realistic operating conditions. The characterization of membranes before and after the testing shows microstructural changes occurring only at the surface of the membranes, however, no major reduction in flux is observed. More study is needed to better understanding of this phenomenon and planned for 2013. SINTEF and UiO have continued a fundamental study on Hydrogen Transport Membranes (HTM) based on La<sub>0.87</sub>Sr<sub>0.13</sub>CrO<sub>3</sub> material. This study showed that in the apparent hydrogen flux measured in a mixture of H<sub>2</sub> and steam, about 80% came from H<sub>2</sub> separation and 20% from steam.

### TASK 1.3 – HYDROGEN COMBUSTION

The research focuses on improving know-how and detailed understanding at the fundamental level about combustion of hydrogen-rich gaseous mixtures, which are relevant for pre-combustion CCS power generation schemes. A novel and possibly groundbreaking fuel injection method has been devised to deliver the hydrogen fuel, through selective membranes, directly into the combustion air of gas turbine burners, and preliminary investigations have been conducted in 2012 to provide a first assessment of the new in-situ separation approach. Other hydrogen-combustion activities carried out in 2012 are the necessary continuations of work started earlier, these include modelling predictions of flame flashback in ducts and experimental investigations of lifted-flame stabilization at pressurized conditions (at UC Berkeley)."



TASK 1.4 – OXY-FUEL COMBUSTION AND FLUE GAS RECYCLE

The objectives are to solve technical challenges related to the burning of fuels in atmospheres of oxygen and CO<sub>2</sub> and to improve the efficiency of post-combustion cycles by the implementation of exhaust gas recirculation. A pressurized oxy-fuel cycle has been set up in cooperation with SP5 that resulted in a 1.7 %-points improved efficiency compared to a baseline case. In collaboration with Mälardalen University (Sweden) it has been shown that a supplementary fired natural gas combined cycle is a very good capture plant candidate provided that the proposed technologies to increase the CO<sub>2</sub> concentration are adopted. Fundamental studies on soot formation and radiation from oxy-fuel combustion have led to the conclusion that higher radiation from oxygen-enriched flames is mainly due to higher temperature. Indeed, the chemical suppression effect of CO<sub>2</sub> on soot has clearly been measured and flames in O<sub>2</sub> - CO<sub>2</sub> environments generate less soot than air flames. A combustion concept for post-combustion capture with Flue Gas Recycle has been tested at DLR in pressurized conditions up to 10 bars and 190 kW, which showed better flame behavior compared to the previously tested swirl burner technology.

TASK 1.5 – APPLICATION TO INDUSTRY AND OFF-SHORE

The potential of various capture routes for specific cases proposed by industrial partners has been studied.

1. Floating Production Storage and Offloading (FPSO) unit: To capture CO<sub>2</sub> from gas turbines on-board an FPSO unit with dual-phase CO<sub>2</sub> separation membranes (experimental study).
2. Reformer-fired heaters in refineries: The feasibility for retrofit of fired heaters for hydrogen combustion (experimental study) and oxy-combustion (experimental study).
3. Aluminum smelter exhaust: To increase the low partial pressure of CO<sub>2</sub> in aluminum exhaust, integration of the exhaust with a gas turbine, and the effect of impurities and dust on the gas turbine and amine capture system were studied. On-site gas turbine filter tests were carried out to measure the impact of impurities on the filter. Additionally, the low temperature process for CO<sub>2</sub> capture from an IGCC was benchmarked for two different gasifier systems – pneumatic feed SHELL and slurry feed GE. Results show that the low temperature capture process results in an improvement in efficiency of 10-15% compared to the Selexol process.

TASK 1.6 – INTEGRATED ASSESSMENT

Two main tracks have been followed for process simulations of integration of novel capture technologies in power plants. The first track is *post-combustion capture from natural gas*, where the integration of calcium looping in the natural gas combined cycle (NGCC) was studied, in collaboration with Task 1.1. Advice for future targets for sorbent stability and cyclic capacity for increased process efficiency was given. Additionally, following the post-combustion track, process simulations were conducted for the NGCC with exhaust gas recirculation, as a means to reduce the energy requirement when capturing CO<sub>2</sub> with solvents. The second track pursued in process simulations, in collaboration with Task 1.2, is *pre-combustion capture from coal* with the Integrated Gasification Combined Cycle (IGCC) process, where focus has been on the integration of palladium membranes for hydrogen separation in an IGCC using a Shell type gasifier. The first results look promising in terms of process efficiency. Additionally, a fundamental activity is ongoing in Task 1.6 to quantify the minimum achievable CO<sub>2</sub> capture penalty with power production from fossil fuels. The thermodynamic minimum penalty for ideal processes was calculated for different fuels for the three different capture routes, as shown in the figure below. Work was also initiated to describe the reasons behind the gap between the ideal and real capture processes and to investigate how much of this gap is possible to close.

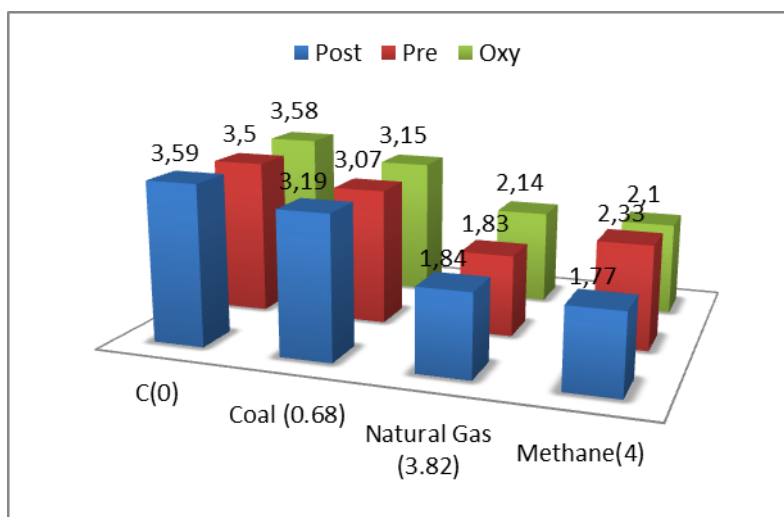

*Ideal process efficiency penalty in percentage points for the three capture routes. Fuel hydrogen/carbon ratio is shown in brackets.*

#### TASK 1.7 – CHEMICAL LOOPING COMBUSTION

CLC is a novel CO<sub>2</sub> capture technology which is seen to have a large potential with respect to efficiency and CO<sub>2</sub> capture cost. In CLC the traditional combustion process is split in two steps. First, a metal oxide material is oxidized by air at high temperature in one reactor. In the second step the oxidized material is reduced by a hydrocarbon fuel in the other reactor. The metal oxide material, the so-called oxygen carrier, is continuously being looped between the two reactors, which are normally arranged as fluidized bed reactors. The oxygen carrier is a corner stone in CLC technology and there will be a need for large quantities produced from less expensive commercial raw materials. A laboratory unit for oxygen carrier production has been installed (figure a, below) and first test production performed. This unit will be used to produce small scale quantities for testing in order to find the best oxygen carrier production recipes. Good candidate materials will be within the CMT type of materials (calcium-manganese-titanium). These oxygen carriers will further be tested under real conditions in a small scale CLC reactor system which has recently been built and operated under CLC mode for the first time. Finally, the best materials will be produced in larger quantities suitable for the 150 kW CLC reactor system which is now constructed and in the commissioning phase (figure b, below).



2a. Powder production unit (Source: SINTEF)

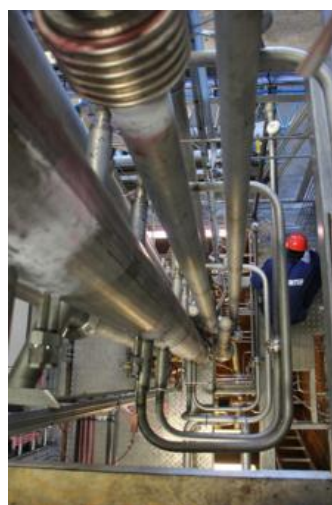

2b. CLC hot rig unit (Source: SINTEF)

TASK 1.8 – CAMPS

The CAMPS sub-project seeks to gain fundamental knowledge targeted to the development of high-fidelity numerical design tools that will ultimately enable energy-efficient and cost-competitive power generation with carbon capture and storage (CCS). The research focuses on technical challenges related to optimization of combustion processes in large, state-of-the-art gas turbines and coal furnaces for power generation. A secondary objective of CAMPS is to strengthen the cross-Atlantic collaboration through the establishment of a US-Norwegian network for combustion research. CAMPS started up in 2012 and in June a seminar titled "Turbulent transport of particles and passive scalars" was organized in Trondheim with international participation. A one-year stay by a SINTEF researcher at Stanford University was initiated in August, and work on oxy-combustion of pulverized coal has been carried out at Stanford with a focus on char gasification and oxidation (WPs 1.1&1.2). Direct Numerical Simulation applied to hydrogen-fired gas turbine combustors has been initiated through collaboration with Sandia National Labs, Livermore, California (WP1.3). Work on cold-flow mixing and the extension of the Linear Eddy Model to variable-density flows has been initiated in collaboration with international consultant Dr. Alan Kerstein (WP2.1). Characterization of atmospheric and pressurized lifted jet flames in vitiated co-flow has been performed at UC Berkeley (WP2.3).

### 7.3 CO<sub>2</sub> TRANSPORT – SP2

SP2 has two tasks:

- Task 2.1: CO<sub>2</sub> pipeline integrity
- Task 2.2: CO<sub>2</sub> mixture properties (started in 2010)

#### TASK 2.1 – CO<sub>2</sub> PIPELINE INTEGRITY

The main objective of this task is to develop a coupled (fluid-structure) fracture assessment model to enable safe and cost-effective design and operation of CO<sub>2</sub> pipelines by improving the fundamental understanding of the interaction between the pipe-material and fluid-dynamical behaviour.

The research-performing partners are SINTEF ER (thermo and fluid dynamics) and SINTEF MC (structural mechanics). The development of the coupled model is proceeding in close collaboration between the two research groups, and by gradual refinement. The work in 2012 concentrated on experimental and numerical characterization of fracture properties of steel materials, and on robust and accurate calculation of the thermodynamic properties of CO<sub>2</sub>, taking into account the formation of solid CO<sub>2</sub> (dry ice), as well as the modelling of flow through cracks. The coupled fluid-structure crack-assessment model is thought to be promising, and to have a potential for future product development.

This task's PhD candidate, Alexandre Morin, was, in November 2012, the first to defend his thesis in BIGCCS. The title was "Mathematical modelling and numerical simulation of two-phase multi-component flows of CO<sub>2</sub> mixtures in pipes". A postdoc was employed task in August 2012, within the topic of nano-scale modelling of crack propagation.

In 2012, the work resulted in two journal papers, and two conference articles and presentations.

#### TASK 2.2 – CO<sub>2</sub> MIXTURE PROPERTIES

This task aims to provide accurate experimental data in selected thermo-physical properties of CO<sub>2</sub>-rich mixtures relevant for CCS. Specifically, the objective is to measure phase state (i.e., the fractions of gas and liquid) at equilibrium, density, and speed of sound for CO<sub>2</sub>-rich mixtures. Such data are needed to calibrate thermodynamic models, which in turn are employed for designing and operating CO<sub>2</sub>-capture and transport systems. Several important gaps have been identified in the measurement data found in the literature.

The work is a collaboration between SINTEF ER, Ruhr-Universität Bochum (RUB), and NTNU. Two PhD candidates are educated in this task. At RUB, a PhD candidate, Robin Wegge, was hired in October 2010, and he has started the work on the speed of sound and density measurement. At NTNU, the PhD candidate Snorre Foss Westman started his work in January 2013. The main task is to perform phase equilibrium measurements.

In 2012, the focus of the work has been to complete experimental rigs needed for the measurements. Measurements of phase equilibria, density, and speed of sound will start in the first half of 2013.

The work resulted in two conference articles and presentations.

SP2 was well represented the International Conference on Greenhouse Gas Technologies (GHGT-11), with three of the above-mentioned conference contributions from Tasks 2.1 and 2.2.

In addition to the Consortium Day presentations, the work in SP2 was presented to the BIGCCS partners in a technical telephone conference, taking place in October.

Below are shown some photos related to the activities in SP2.



*Test cell for measurement gas-liquid composition of CO<sub>2</sub>-rich mixtures at equilibrium. (Source: SINTEF)*

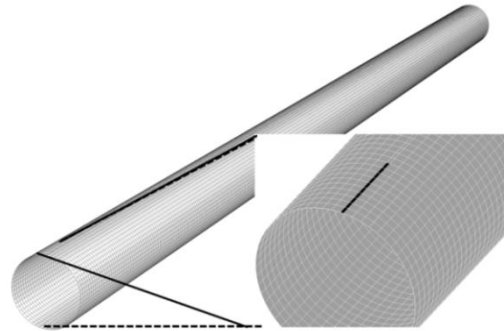

*Illustration of finite-element mesh with predefined crack path (highlighted). (Source: SINTEF)*



*Illustration of shear fracture surfaces in small-scale steel test specimens. (Source: SINTEF)*

## 7.4 CO<sub>2</sub> STORAGE – SP3

SP3 consists of the following four tasks:

- Task 3.1: Qualification and management of storage resources
- Task 3.2: Storage behaviour
- Task 3.3: Monitoring, leakage and remediation
- Task 3.4: Fundamental effects of CO<sub>2</sub> on rock properties

### TASK 3.1 – QUALIFICATION AND MANAGEMENT OF STORAGE RESOURCES

#### *CO<sub>2</sub> capacity estimation and large scale modeling of CO<sub>2</sub> injection*

BGS has continued the work on static and dynamic CO<sub>2</sub> storage capacity estimates and large-scale modelling of CO<sub>2</sub> injection into the Bunter Sandstone in the UK sector of the Southern North Sea. The modelling provides simplified representation of the NW part of the Bunter Sandstone Formation. The model does not include reservoir heterogeneity. Nevertheless it is clear that pore fluid pressure rise could be a significant issue at a considerable distance outside the CO<sub>2</sub> footprint at the end of the injection period, particularly where the reservoir is at shallow depths. The results of the modelling give a very broad indication of the scale of CO<sub>2</sub> injection that could be possible and the strategy that might be employed to maximize storage whilst not exceeding a limiting pore fluid pressure increase. With 12 injection points, approximately 15 – 20 Mt CO<sub>2</sub> per year can be injected into the model for 50 years without exceeding 75% of the lithostatic pressure anywhere within the model (0.75 – 1.0 x 10<sup>9</sup> tonnes in total). In a recent variant model with 92 Mt CO<sub>2</sub> per year the CO<sub>2</sub> saturation and pressure development after 50 years of injection through 10 wells are shown in the figure below.

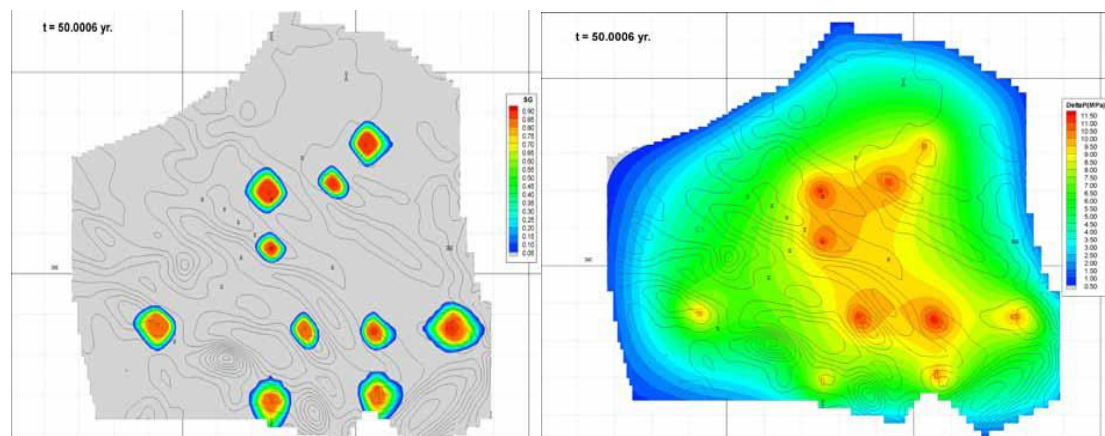

CO<sub>2</sub> saturation (left) and pressure development (right) after 50 years of CO<sub>2</sub> injection. (Source: BGS)

#### *CO<sub>2</sub> storage with active water production*

The simulation work on pressure management, capacity estimation and water production to increase CO<sub>2</sub> storage volume and prevent over-pressuring of the CO<sub>2</sub> storage site is continued at GEUS. Example from the modelling work is shown in the figure below of the overpressure in the area for the case study. The water production from the four wells at the margin of the storage site limits the propagation of the pressure to the surrounding region significantly.

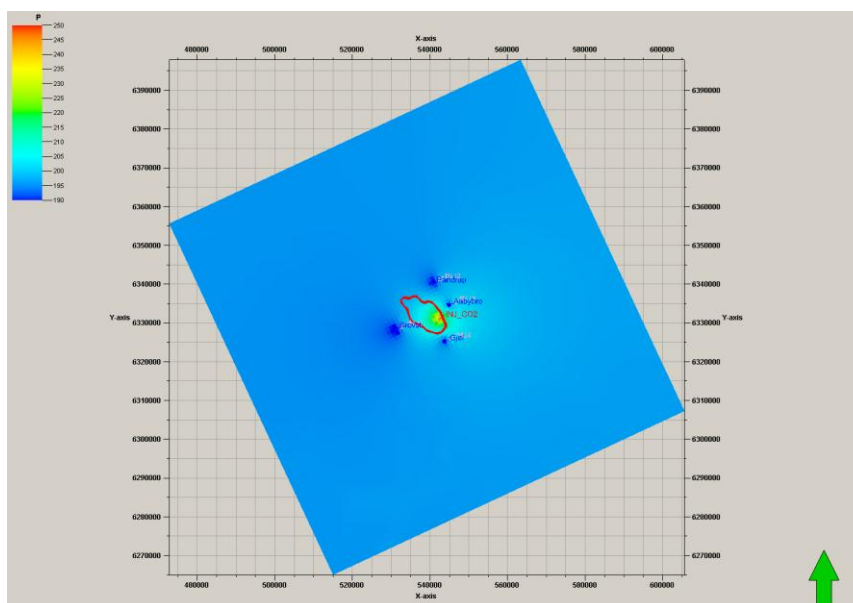

Simulation of pressure after 40 year of CO<sub>2</sub> injection and simultaneous water production with voidage +90% (w/w) corresponding to ~3 million tons net production of Geothermal Energy water (400 m<sup>3</sup>/h). Injection rate: 100 kg/sec corresponding to 3.15 million tons CO<sub>2</sub> per year. The map shows water potential referred to a reference level, and therefore the equivalent overpressure due to injection. (Source: GEUS)

### TASK 3.2 – STORAGE BEHAVIOUR

#### Convective mixing

Diffusion induced convection is considered a medium to long-term trapping mechanism for CO<sub>2</sub> in the underground as the gravity driven mixing process increases the dissolution rate of CO<sub>2</sub> in the aquifer brine significantly. The timing of this onset of convective mixing in real aquifers can vary from probably less than a year to hundreds of years depending on geology mainly. The mathematical model for this physical mechanism has been studied for more than 30 years in the literature, and the theoretical work in task 3.2 aims at working out a mathematical proof for the value of onset times, thereby closing this problem once and for all. Recently, *new theorems have been proven* in operator theory that points out a clear plan for the final part of the proof of the correctness of the proposed values for (the critical) onset times and the corresponding critical wave numbers. The results achieved so far were presented at ECMOR XIII in September 2012.

There has been performed *experimental and numerical work* on both convective mixing and on capillary trapping (yet another trapping mechanism), where the experimental work has been performed in 2D Hale-Shaw cells with visual observation and in a closed cell using mass balance accounting to assess dissolution rates. The latter experiments have also been performed using layered type of heterogeneities. Experiments are matched with numerical simulations, verifying the physical model of the processes *Simulations of capillary trapping* in fine scale (mm-cm), realistic geological features have also been modeled numerically. The simulations show how one can "hyper-trap" additional CO<sub>2</sub> in such heterogeneous models.

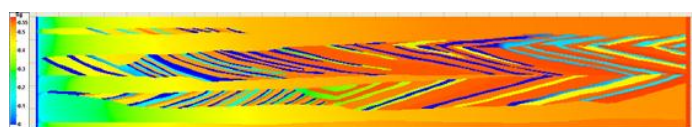

Saturation plot of capillary trapped CO<sub>2</sub> in a fine scale representation of a geological unit. (Source: GEUS)

Finally, a link between theoretical results and the practical issue of representing the fine scale (10cm-5m) physics of convective mixing in field scale simulations has been identified. This is relevant for *up-scaling*, and subsequent work on this issue takes place in 2013.

### TASK 3.3 – MONITORING, LEAKAGE AND REMEDIATION

#### *Seismic monitoring*

The technique of spectral decomposition is shown to be a potentially useful tool in assessing CO<sub>2</sub> layer thicknesses in complex geological environments. The method works by extracting discrete signal frequencies from seismic data from a narrow zone to estimate the thickness of sound wave reflectors at a resolution below the tuning thickness, corresponding to the tuning frequency. A small analysis window is required to isolate reflections from the individual CO<sub>2</sub> layers, e.g. at Sleipner, consequently conventional time-frequency analysis techniques suffer from resolution problems: a narrow analysis window localizes the spectrum in time but provides poor frequency resolution. This study is based on computing auto-correlation over all possible seismic signal time lags and extracting all frequency components. Decreasing frequency content is shown to indicate increasing CO<sub>2</sub> layer thickness.

#### *Leakage*

An experimental set-up for investigating de-bonding of cement and formation has been tried. The geometry for these tests is hollow cylinder rock plugs, where the cement is poured into the borehole, allowed to set at atmospheric conditions and then displaced using a load frame with a small piston the size of the cement plug. Focused Ion Beam – Scanning Electron Microscope (FIB-SEM) has been retained, together with micro-CT imaging, as the technique to analyze the geometry of laboratory created micro-cracks between cement sheath and surrounding formation. The instrument has nano/micro scale resolution and allows for localized chemical analyses. The procedure is illustrated in the figure below. Test-volumes on cement and shale (cap rock) have recently been recorded.

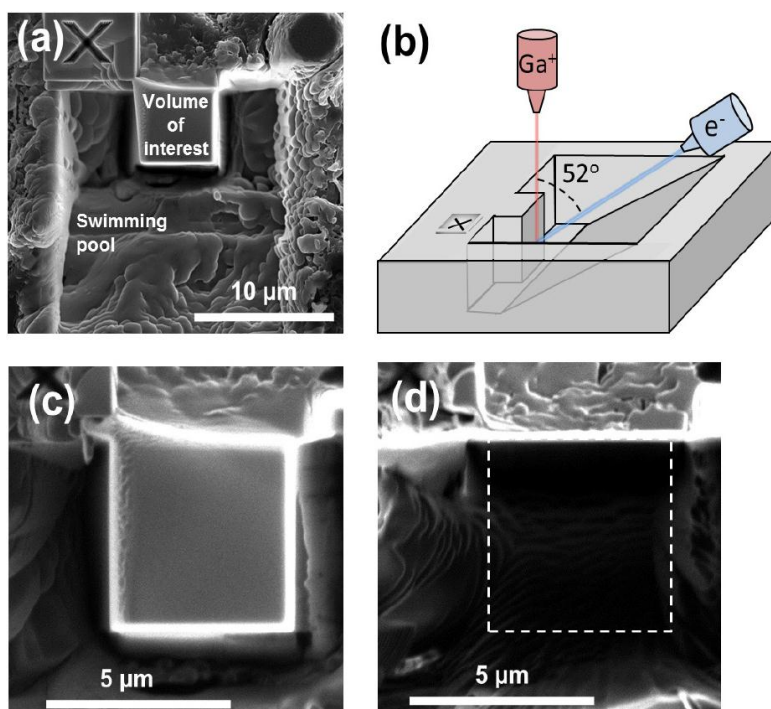

(a) The sample surface before analysis, (b) schematic overview of the FIB-SEM technique, (c) the volume of interest before the cutting procedure, (d) the sample after the volume of interest has been sliced up and analyzed. (Source: SINTEF)



### Task 3.4 – Fundamental effects of CO<sub>2</sub> on rock properties

#### *Geomechanics and near-well integrity*

The stream of CO<sub>2</sub> inside an injection well will have a temperature different from the initial rock temperature around the well. The temperature difference will depend on the surface transport method (ship/truck/off- and onshore pipeline) and on the reservoir depth. This temperature difference will create stresses in the well construction and in the formation surrounding the well. Modeling performed at SINTEF under Task 3.4 shows that in some cases the stresses could be large enough to create fractures in the casing/cement bond or in the formation, possibly opening leakage pathways for the injected CO<sub>2</sub> from the storage formation and up to shallower formations or to the surface (see illustration in the figure below). It is therefore important that such possibilities are taken into consideration in the planning of the injection operation.

Storage formations for CO<sub>2</sub> could be bounded by sealing faults, or the confining seal above the storage formation could contain such faults. The injection of CO<sub>2</sub> into the storage formations will gradually change the pore pressure in the formation. To ensure storage safety it is important to keep the formation pressure at a level below the point where the sealing faults may be re-activated and become conductive. As part of the work in Task 3.4 a custom-built laboratory apparatus is being prepared at BGS for tests that will investigate the re-activation mechanisms for sealing faults under various pore-pressure induced changes in the stress conditions. The tests will also characterize the flow properties in the faults during and after the re-activation.

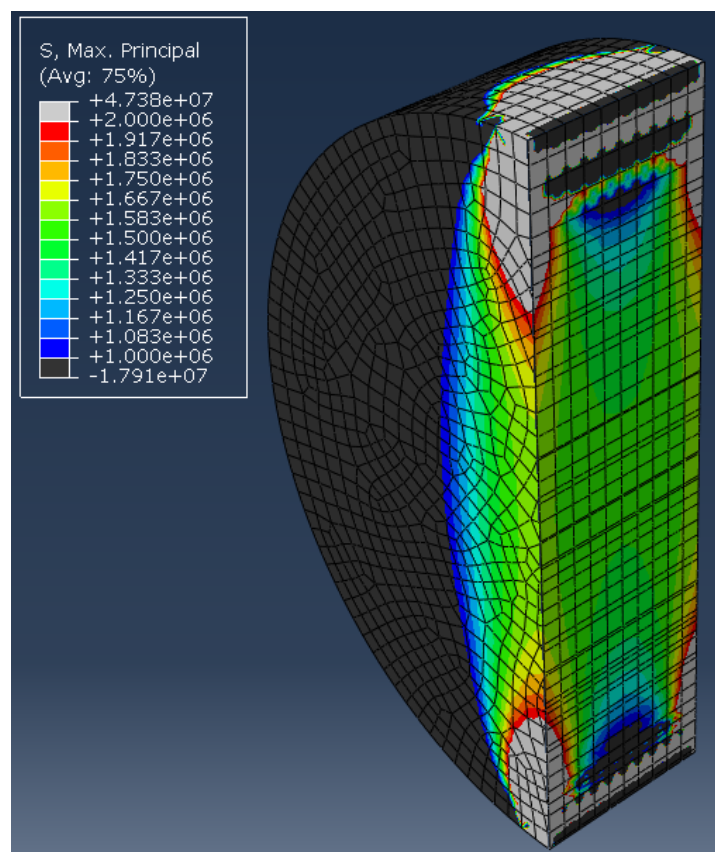

*Example of result from simulation of laboratory test to examine temperature-related stress in a disc shaped sample (half the disc is displayed in the model). (Source: SINTEF)*

## 7.5 CO<sub>2</sub> VALUE CHAIN – SP4

SP4 has two tasks:

- Task 4.1: CO<sub>2</sub> chain analysis: techno-economical and environmental impacts and safety
- Task 4.2: Economy and policy incentives for the CO<sub>2</sub> chain

### TASK 4.1 – CO<sub>2</sub> CHAIN ANALYSIS: TECHNO-ECONOMICAL AND ENVIRONMENTAL IMPACTS AND SAFETY

One of the main objectives of this task is to develop methods for assessing CCS value chains and to determine cost-effective, environmentally friendly, and safe options for CCS. In 2012, Task 4.1 developed even further the methodology for such a multi-criteria assessment of CCS chains. This methodology involves designing CCS chains using a "modular" approach where each part of the chain – capture, transport, and storage – is treated as its own module and can be connected in various ways to create CCS chains to study in detail. This approach is thus flexible and can be used to answer a variety of important questions surrounding CCS. The focus in 2011 was on developing the capture module for post-combustion amine capture and in 2012, modules for transport for on-shore pipelines and shipping have been created and tested on simple case studies.

The techno-economic modeling utilizing *AspenPlus* and *Aspen Economic Analyzer* have been combined in a consistent manner with input-output life cycle assessment (LCA) methods to ensure complete consistency. The methodology and the newly-added transport modules were illustrated through a simple case study to illustrate and compare the technical, economic, and climate impact performance of an onshore pipeline versus CO<sub>2</sub> shipping between two onshore harbors for a wide range of distances and CO<sub>2</sub> capacities. This type of assessment and case study has provided new insight, as previous studies have not systematically included CO<sub>2</sub> capacity and transport distance before. In addition, sensitivity analyses were conducted to show the relative importance of regional effects of pipeline costs, first-of-a-kind effects, ownership effects, geographical contexts, effects of CO<sub>2</sub> fluctuations, uncertainties on the future of CCS and financial risks, and the future energy prices. This case study has been submitted to the *International Journal of Greenhouse Gas Control*. In 2013, the second part of this work will be to compare transport technologies for transport between coastal areas and an offshore area. This will be completed through the development of additional transport modules for offshore pipelines and shipping between a harbor and an offshore area.

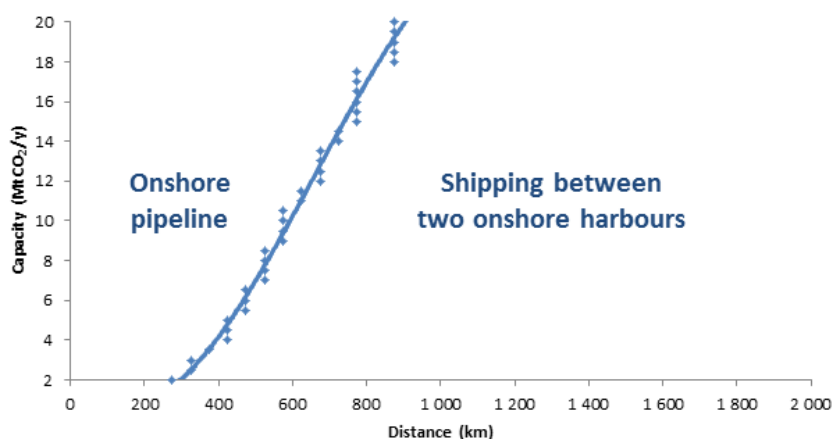

Example of the "switching" curve for selecting the appropriate transport technology for a given case study (transport between two onshore harbors via onshore pipeline or shipping). (Source: SINTEF)

TASK 4.2 – ECONOMIC AND POLICY INCENTIVES FOR THE CO<sub>2</sub> CHAIN

A main objective of this task is to explore economic and policy barriers to CCS development and deployment, as well as policy tools that can overcome such barriers. Two important issues in this regard are the value of CCS and factors driving public perceptions of CCS.

Earlier economic studies on CCS have not considered the tension between the benefits of CCS and the costs associated with the possibility of leakage of CO<sub>2</sub> from geological storage sites. The scale at which CCS should be deployed must also be seen in light of future costs if CO<sub>2</sub> leakage should occur. A dynamic economic model of allocation of CO<sub>2</sub> reductions is introduced to analyze these issues, including CCS with a possibility of leakage from geological storage sites. To the extent that CO<sub>2</sub> leakage rates are uncertain and causes delayed temperature increase, correct pricing of CO<sub>2</sub> storage (and CCS) requires that present CO<sub>2</sub> emissions captured through CCS to be offset more than proportionally. This means that the value of mitigating one ton of CO<sub>2</sub> through CCS is less than mitigating one ton of CO<sub>2</sub> through e.g. replacing coal power with wind power. Present carbon pricing may not reflect the fact that firms or states responsible for stored CO<sub>2</sub> do not internalize remediation costs that may occur in the future.

The study of public perceptions of CCS is based on a comprehensive survey of citizens in a selection of US municipalities. In some of the municipalities the coal industry is a cornerstone. Views on CCS and wind power as solutions to the climate challenge are examined, as well as a views on government funding of R&D on CCS and wind. After examining the impact of worldview (cultural and social factors unrelated to specific technologies) and economic interest (e.g. work in the coal industry) a main finding is that framing the issue as a government funding question will trigger different responses according to the worldview of people, whereas framing the issue as supporting deployment of these technologies will trigger much broader public support.

## 7.6 ACADEMIA – SP5

The *recruitment* efforts in BIGCCS only involved two researchers in 2009, but peaked already in 2010 (14 researchers), followed by four recruitments in 2011 and five recruitments in 2012. The total work force of recruited researchers in BIGCCS was 25 by the end of 2012, with 19 PhDs and six Post-docs.

The volume of *publications* in 2012 was considerable, and a trend has been more journal publications and fewer conference publications. This is quite normal and a wanted situation; it is easier to start with conference publications and presentations and then gradually move into the more challenging journal publications. The accumulated list of publications by the end of 2012 shows the following statistics:

- Journal Publications: 18 (five during 2011)
- Conference Publications: 14 (18 during 2011)

Some of the conference publications will be converted into journal publications next year. It should be noted that the list of publications here only refers to publications where one or more of the PhDs and Post-docs recruited in BIGCCS are among the authors, the total publication volume in BIGCCS is reported elsewhere in this Annual Report.

In order to assist in giving the recruited researchers a feeling of belonging to the BIGCCS “family”, one day or half a day *seminars* have been arranged. In 2012, the “PhD/Post.doc Seminar” was arranged on 20 September as part of the Consortium Days. This resulted in a good attendance from industrial and other partners, and 16 presentations were given in six small sessions.

Regarding highlights from the *research* activities that the PhD students and Post.docs are involved in; these are more appropriately reported under the headings of the relevant Sub-Projects (SP1-SP4).

## 7.7 DELIVERABLES

BIGCCS had in 2012 121 deliverables. This includes publications, technical reports, status reports, technical memos, and anything that can be associated with the regular and planned operation of the Center. In addition to the planned deliverables BIGCCS had 61 publications (an overview of publications is given in Chapter 10). The table below shows how the deliverables are distributed among the Sub-projects.

<b>Sub.project</b>	<b>Deliverables</b>
SP1	65
SP2	22
SP3	12
SP4	15
Centre mgmt	7
<b>Total</b>	<b>121</b>

*BIGCCS deliverables in 2012*

## **8. INTERNATIONAL COOPERATION**

International cooperation is a central and integral part of the BIGCCS activities. Through the participation of strong European industry partners and highly ranked international R&D providers, the BIGCCS Centre maintains a high international profile. Seven nations are currently represented, including the industrial participants: *ConocoPhillips* (USA/Norway), *GDF Suez* (France/Norway), *TOTAL* (France/Norway), *Shell* (Netherlands/Norway), and the research institutes *DLR* (Germany), *TUM* (Germany), *GEUS* (Denmark), and *BGS* (UK). In addition, several research groups work in close collaboration with researchers from other international research institutes and universities. The partners play active roles within the various research tasks, and as members of the different BIGCCS committees.

### COOPERATION WITH INTERNATIONAL RESEARCH GROUPS OUTSIDE BIGCCS

BIGCCS continues cooperation with:

- *University of Berkley* (California, USA) and Professor Robert Dibble. University of Berkley is one of the world leading research groups on combustion.
- The *Combustion Research Facility at Sandia National Laboratory*, USA, which is the U.S. Department of Energy's premier site for research in combustion technology.
- *Ruhr Universität Bochum* and Professor Roland Span. This research group is among the highest ranking in the field of characterization of CO<sub>2</sub> and CO<sub>2</sub> mixtures.
- *Nordic CCS research Centre* (NORDICCS). This is first and foremost a networking collaboration between R&D institutes and the industry in the Nordic countries with focus on CCS deployment.
- *European Carbon dioxide Capture and Storage Laboratory Infrastructure* (ECCSEL). The mission is to ECCSEL is to develop a European distributed, integrated Research Infrastructure, involving the construction and updating of research facilities.
- *The Impact of the Quality of CO2 on Transport and Storage Behaviour* (IMPACTS). A FP7 project led by SINTEF that will close critical knowledge gaps related to transport and storage.

### COOPERATION WITH INTERNATIONAL ORGANIZATIONS

- BIGCCS personnel are actively participating in activities spearheaded by the following international organizations: International Energy Agency, The European Energy Research Alliance (EERA), Global CCS Institute (Australia), National Institute of Advanced Industrial Science and Technology (Japan), CORIA-Université de Rouen (France), Corning S.A. (France), Air Liquide (France), SGU (Sweden), TNO (the Netherlands), IFP (France), Colorado School of Mines (USA), and Freie Universität Berlin (Germany). Through the two last amended KPN projects we also cooperate with: North Carolina State University, RWTH Aachen University, Georgia Tech, Brigham Young University, National Renewable Energy Lab, and Stanford Univ.

### ORGANIZATION OF CONFERENCES, WORKSHOPS AND SEMINARS

BIGCCS is the organizer of the 7<sup>th</sup> *Trondheim CCS Conference (TCCS-7)* to be held June 4-6, 2013. Following the success of TCCS-6 (2011) with 425 participants, it is interesting to note that the number of abstracts received this time is at the same level as at the previous conference – more than 260. A great deal of planning and preparations were done in 2012. More information about TCCS-7 can be found here: <http://www.sintef.no/tccs-7>

BIGCCS aims at becoming the organizer of the *GHGT*-conferences. A joint SINTEF-NTNU application was submitted in 2012 to host the GHGT-13 in 2016. A decision in this matter is expected before the summer 2013.

## 9. RECRUITMENT

The overall recruitment objective is for BIGCCS to produce 18 PhDs and eight Post-doc candidates. Three PhDs and one Post-doc were recruited in 2012. This brings the total work force of recruited researchers in BIGCCS up to 25 by the end of 2012, with 19 PhDs and six Post-docs.

The total work force of PhDs and Post-docs is now as follows:

- 13 PhDs and 6 Post-docs at NTNU, Trondheim, Norway
- 2 PhDs at the University of Oslo (UiO) – one funded by BIGCCS and one as an “in kind” contribution from UiO
- 1 PhD at the Technical University of Munich, Germany
- 2 PhDs at University of California, Berkeley, USA (associate partner)
- 1 PhD at Ruhr University, Bochum (associate partner)

Among the 25 recruited researchers, one PhD (Alexandre Morin, 2012) and two Post-docs (Anwar Bhuiyan, 2011, and Hassan Karimaie, 2012) have completed their tasks. Seven out of the 25 candidates are female researchers, and 10 countries are represented, thus a highly international group of researchers.

The distribution of candidates between county and gender is shown in the figure below.

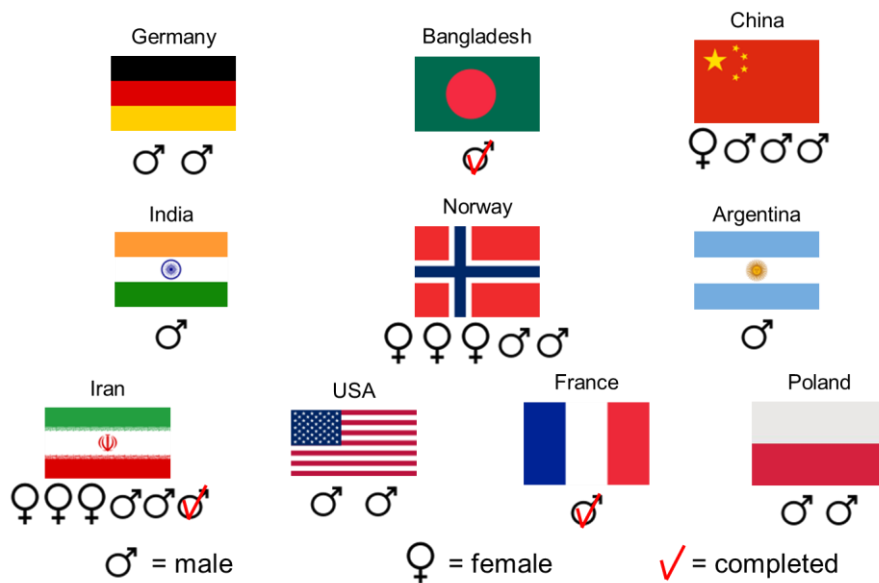

Distribution of PhD and Post-doc candidates between country and gender. (Source: Prof. Truls Gundersen)

## 10. COMMUNICATION AND DISSEMINATION

BIGCCS seeks to be a source for objective information on research and development, status and potentials of CCS at several levels, i.e. for the research community, for decision makers, and for the public. Different instruments and communication channels are used for the different target groups. Below is highlighted some of the work carried out in 2012.

### PUBLICATIONS

BIGCCS has a strong emphasis on publishing the results from the R&D activities. High-ranking scientific journals are much preferred to reports. The table below gives an overview of the publication figures for 2012, as well as for the first four years of the BIGCCS project.

Publication type	2009	2010	2011	2012	Total
<b>Book sections</b>			1	2	3
<b>Conference papers</b>	4	41	45	66	156
<b>Journal articles</b>		5	17	30	52
<b>Magazine articles</b>	1	4		2	7
<b>Annual reports</b>		1	1	1	3
<b>Newspaper articles</b>			1		1
<b>TOTAL</b>	5	51	65	101	222

### ORGANIZATION OF CONFERENCES

The BIGCCS Centre receives a high public profile by organising *the Trondheim Conference on CO<sub>2</sub> Capture Transport and Storage (TCCS)*, which has become a major scientific CCS conference. BIGCCS had a central role in organizing the TCCS-6 conference in 2011, and started in 2012 the preparations for the TCCS-7 conference to be held in 2013.

It is the ambition of the BIGCCS Centre to be the organizer of one of the next *GHGT*-conferences. A joint SINTEF-NTNU application was submitted in 2012 to host the GHGT-13 in 2016. A decision in this matter is expected before the summer 2013.

### PARTICIPATION AT GHGT-11

BIGCCS researchers contributed with six oral presentations and 19 poster presentations at the GHGT-11 conference in Kyoto, Japan, November 25-28. This conference is the world's largest CCS conference, and was attended by more than 1000 delegates. The photos below are from the poster session showing BIGCCS researchers in front of their posters.

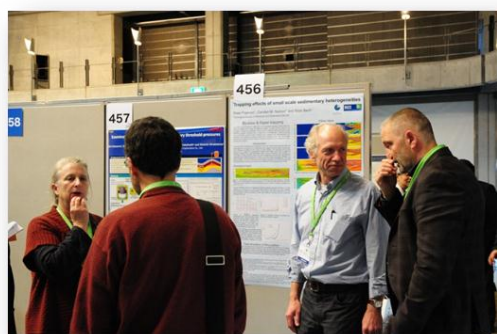

Left: Prof. Susan D. Hovorka, BIGCCS Scientific Com., and Peter Frykman (blue shirt), GEUS.  
(Source: Svend Tollak Munkejord)



Right: Sigurd W. Løvseth, SINTEF and Prof. Roland Span, Ruhr Univ. Bochum. (Source: Nils Røkke)

BIGCCS and the NORDICCS project attended the GHGT-11 conference, with a joint exhibition booth. The booth received significant publicity.



*BIGCCS' exhibition booth at GHGT-11 in Kyoto, Japan. Posing proudly: Rune Bredesen, Mario Ditaranto, Sigurd W. Løvseth, and Svend Tollak Munkejord. (Source: Nils Røkke)*

#### SPECIAL ISSUE OF ENERGY PROCEDIA

All authors, both oral and poster, at the TCCS-6 conference (2011) were offered the possibility to make scientific publications of their contributions. A special issue will be made from the conference through Energy Procedia. This issue was published in the summer of 2012, and contained around 60 scientific papers.

#### SINTEF AND NTNU CCS AWARD

SINTEF and NTNU initiated in 2011, *the SINTEF and NTNU CCS Award*. The second award will be presented at the TCCS-7 in 2013. The Award is given to individuals for outstanding achievements within the field of carbon capture, transport and storage (CCS), and includes a stipendium of NOK 25,000, a plaque, and free participation at the next TCCS conference.

#### ROADMAP

For the purpose of communicating goals, strategies, and technology developments in the BIGCCS Centre, a *technology roadmap* has been developed. The intention with the roadmap is that each task, in a simple way, manages to visualize where the different technologies are at present, and how they will develop during the course of the project. The roadmap will be updated in 2013.

#### OTHER PLATFORMS

Other important platforms for communication and information dissemination are the:

- Consortium Day – focus is on the whole project
- Technical Meetings – focus on research activities in the different tasks
- Newsletters (three issues were produced in 2012)



## **11. INNOVATION AND CENTRE BUILDING**

The core of BIGCCS's mandate is to develop research-based knowledge and technologies that contribute towards realization of efficient industrial carbon capture, transport, and storage technologies. In so doing, the Center is given a significant mission for reducing the carbon footprint of fossil-based energy production.

Innovation activities in 2012 has focused along three axes; activating the Exploitation and Innovation Advisory Committee, development of spin-off projects, and preparations for establishment of a new body under BIGCCS with the working title "BIGCCS Innovation".

The ***Exploitation and Innovation Advisory Committee*** (EIAC) has analyzed innovation opportunities in BIGCCS based on self-assessments from all the task leaders. The analysis has resulted in a set of recommendations to the Centre; including a listing of concrete results that might have a commercial potential. The Centre Management Group (CMG) and the Board will continue to work together with the EIAC to develop innovation strategies and concrete plans for innovation possibilities. The EIAC has members from the following industrial partners: Statoil, Gassco, GDF Suez and Shell.

Two new ***spin-off projects*** intended to be included in the BIGCCS portfolio has been granted by the RCN during 2012 – this is *Novel hybrid membranes for post combustion CO<sub>2</sub> capture in power plant and industry* (HyMemCOPI) and *BIGCLC Phase III*. In addition, the EU project *The Impact of the Quality of CO<sub>2</sub> on Transport and Storage Behaviour* (IMPACTS) was granted and will be in operation from 2013. Though not formally a part of BIGCCS, this project will be of great importance, and is complementary, to the activities in SP2.

In 2012, ideas and possibilities for establishing a separate body under BIGCCS with a narrow focus on innovation possibilities have been discussed in the CMG. This work is a follow-up from the report that was delivered to the Board from the EIAC. The working title for this body is ***"BIGCCS Innovation"***, and the intention is to bring in new members, especially vendors, which can contribute in pinpointing concrete innovation possibilities, as well as participate in the development of new technologies and products. This idea will be discussed further with the Board in 2013, and the intention is to have the body established in 2013.

## **12. HEALTH, SAFETY AND ENVIRONMENT**

Below are described some of the activities BIGCCS has focused on during 2012, and the HSE statistics for the year.

### **12.1 SPECIFIC ACTIVITIES IN 2012**

A cooperation agreement has been developed between SINTEF Energy Research and NTNU's Institute for Energy and Process Engineering. The aim is to coordinate and harmonize the organizations' two HSE regimes, and to clarify responsibilities between the two. The agreement focusses on: responsibilities for employees and a sound and safe working environment, information exchange, planning of activities, joint internal control related to joint activities.

#### SAFETY ASSESSMENT FOR TRAVEL ACTIVITIES

Cooperation with international partners requires traveling activities. A risk assessment is mandatory whenever SINTEF personnel undertake business travel outside the EU/EEA area, USA and Canada. The assessment must be approved by the immediate supervisor prior to departure, and includes health and safety issues. In cases of travel to countries/areas currently subject to activities or conflicts that may result in increased risk to employees, an evaluation must be obtained from the SINTEF Security Manager and HSE Manager prior to departure. Members of large groups, for example from single departments or institutes, are not all allowed to travel in the same transport vehicle. Each department within the research divisions/companies must keep records of its employees' travel plans, so that SINTEF can contact the employee in question.

#### SAFETY ASSESSMENT FOR LABORATORY VISITS

In general, SINTEF has a conservative policy in terms of admitting visitors to laboratory areas. No visitors are admitted without a good cause. From time to time, however, individuals and groups are admitted to see laboratory test rigs, and then under a strict regime. The responsible for the visit will send a request to the Laboratory Manager (LM), with information about the visitors, the purpose of the visit, the part of the laboratory to be visited, and an evaluation of the necessity for additional risk evaluations. The LM then makes an independent risk assessment for the visit, and requests approval (or recommends rejection) from the responsible Research Director (RD). All visitors are required to wear prescribed personal protective equipment, and to wear a visitor's badge. All visitors are duly registered before the visit.

#### HSE COURSE FOR PERSONNEL WITH ACCESS TO LABORATORIES

Regular SINTEF and NTNU employees as well as NTNU students are required to complete a special training course in order to obtain access to the SINTEF and NTNU laboratories (operated by SINTEF Energy Research and NTNU institutes "Electric Power Engineering" and "Energy and Process Engineering"). The course only gives access to the laboratories. Working with certain test rigs, equipment and for instance specific gases, may require additional training.

#### HSE IN FIELDWORK

The area of fieldwork is one of the areas where SINTEF and BIGCCS wish to establish more concrete procedures and guidelines. This work has been initiated in 2012 and will be an important activity in 2013.

**12.2 ACCIDENTS, INCIDENTS, ETC.**

A *dangerous condition* was identified during 2012. An investigation, in accordance with SINTEF's own procedures was conducted in the aftermath. Appropriate corrective actions have been taken.

A *near accident* happened during December 2012 in SINTEF Energy Research's laboratory. Actions have been taken both on the SINTEF and the NTNU side to ensure that similar incidents are avoided in the future.

The project involves no experiments with persons, no personal data, and no risk for humans, animals or nature. There is nothing about the means or methods in the project that violates the values of society.

**ATTACHMENTS**

ATTACHMENT 1: PERSONNEL

ATTACHMENT 2: ACCOUNTING REPORT

ATTACHMENT 3: PUBLICATIONS

**A1. PERSONNEL****KEY RESEARCHERS**

NAME	AFFILIATION	DEGREE	SEX	POSITION
Alexandre Lavrov	SINTEF PR	PhD	M	Senior researcher
Alv-Arne Grimstad	SINTEF PR	PhD	M	Senior researcher
Andrea Gruber	SINTEF ER	PhD	M	Senior researcher
Bjarne Malvik	SINTEF ER	Dr.ing.	M	Research scientist
Bjørnar Arstad	SINTEF MC	PhD	M	Research scientist
Børge Arntsen	NTNU	PhD	M	Professor
Cato Dørum	SINTEF MC	PhD	M	Senior scientist
Christian Thaulow	NTNU	PhD	M	Professor
Dag Wessel-Berg	SINTEF PR	PhD	M	Senior researcher
Erik Lindeberg	SINTEF PR	PhD	M	Chief scientist
Gareth Williams	BGS	PhD	M	Geophysicist
Grethe Tangen	SINTEF PR	PhD	F	Senior scientist
H. G. Jacob Stang	SINTEF ER	Dr.ing.	M	Research scientist
Hanne Kvamsdal	SINTEF MC	PhD	F	Senior researcher
Hugo A. Jacobsen	NTNU	PhD	M	Professor
Idar Akervoll	SINTEF PR	MSc	M	Senior researcher
Inge R. Gran	NTNU	PhD	M	Professor
Jacob Stang	SINTEF ER	Dr.ing	M	Research scientist
James White	BGS	PhD	M	Geophysicist
Jan Åge Stensen	SINTEF PR	PhD	M	Researcher
Jana P. Jakobsen	SINTEF ER	PhD	F	Senior scientist
Jens-Petter Andreassen	NTNU	PhD	M	Ass. Professor
Jon Kleppe	NTNU	PhD	M	Professor
Jyh-Yuan Chen	UC Berkeley	PhD	M	Professor
Karen Lyng Anthonson	GEUS	MSc	F	Geo-engineer
Karl Anders Hoff	SINTEF MC	PhD	M	Research scientist
Kristin Jordal	SINTEF ER	PhD	F	Research scientist
Magne Hillestad	NTNU	PhD	M	Professor
Marie-Laure Fontaine	SINTEF MC	PhD	F	Senior researcher
Martin Landrø	NTNU	PhD	M	Professor
May-Britt Hägg	NTNU	PhD	F	Professor
Mona J. Mølnevik	SINTEF ER	PhD	F	Research director
Nils A. Røkke	SINTEF ER	PhD	M	Vice-president
Ole Thorsæter	NTNU	PhD	M	Professor
Øyvind Langørgen	SINTEF ER	MSc	M	Research scientist
Partow P. Henriksen	SINTEF MC	PhD	F	Research manager
Peter Frykman	GEUS	PhD	M	Senior researcher
Pierre Cerasi	SINTEF PR	PhD	M	Senior researcher
Rahul Anantharaman	SINTEF ER	PhD	M	Research scientist
Rasmus Rasmussen	GEUS	PhD	M	Senior advisor
Reidar Haugsrud	UiO	PhD	M	Ass. Professor
Richard Blom	SINTEF MC	PhD	M	Research manager
Robert Drysdale	SINTEF PR	PhD	M	Senior advisor
Robert W. Dibble	UC Berkeley	PhD	M	Professor
Roland Span	Ruhr Univ B.	Dr.ing.	M	Professor
Rune Bredesen	SINTEF MC	PhD	M	Research director
Sigmund Ø. Størset	SINTEF ER	MSc	M	Research manager
Sigurd Sannan	SINTEF ER	PhD	M	Research scientist

Sigurd W. Løvseth	SINTEF ER	Dr.ing.	M	Research manager
Svend T Munkejord	SINTEF ER	PhD	M	Senior scientist
Terese Løvås	NTNU	PhD	F	Professor
Thomas Østerlie	NTNU SR	PhD	M	Senior researcher
Thomas Sattelmayer	TU München	Dr.ing.	M	Professor
Tone M. Berg Aasen	NTNU SR	PhD	F	Research manager
Tor Grande	NTNU	PhD	M	Professor
Truls Gundersen	NTNU	PhD	M	Professor
Yngve Larring	SINTEF MC	PhD	M	Senior researcher
Zhijun Du	SINTEF PR	PhD	M	Senior researcher
Olav Bolland	NTNU	PhD	M	Professor

#### PH.D. STUDENTS WITH FINANCIAL SUPPORT FROM THE CENTRE BUDGET

Name	Nationality	Period	Sex	Topic
North, Andrew	USA	2010-2013	M	Numerical modeling of lifted H <sub>2</sub> /N <sub>2</sub> jet flames at pressurized conditions
Frederick, Don	USA	2010-2013	M	Experimental investigation of lifted H <sub>2</sub> /N <sub>2</sub> jet flames at pressurized conditions
Baumgartner, Georg	Germany	2010-2013	M	Experimental investigation of hydrogen flashback behaviour in turbulent boundary layers
Sánchez, Rafael Antonio	Argentina	2010-2013	M	Modeling and simulation of sorption-enhanced steam methane reforming (SE-SMR) operated in circulating fluidized bed reactors
Taheri, Amir	Iran	2010-2014	M	Experimental study of CO <sub>2</sub> dissolution in brine aquifers
Soroush, Mansour	Iran	2010-2014	M	Modelling and simulation of different phenomena in CO <sub>2</sub> storage
Ystad, Paul	Norway	2010-2014	M	Process dynamics related to post-combustion CO <sub>2</sub> capture
Nafisi, Vajiheh	Iran	2010-2014	F	Nano-structured low temperature membranes
Chen, Xinzhi	China	2010-2014	M	Dense ceramic membranes for separation-high temperature mechanical performance and chemical/mechanical stability

Grude, Sissel	Norway	2010-2014	F	Seismic monitoring of CO <sub>2</sub> injection
Vøllestad, Einar	Norway	2010-2014	M	Characteristics of mixed proton cond. materials
Ma, Xiaoguang	China	2010-2014	M	Absorption in precipitating Systems
Wegge, Robin	Germany	2010-2013	M	CO <sub>2</sub> mixture properties
Enaasen, Nina	Norway	2011- 2013	F	CO <sub>2</sub> separation
Soundararajan, R.	India	2011-2014	M	Oxy-fuel combustion
Nilsen, Espen Birger	Norway	2011-2014	M	Monitoring, leakage and Remediation
Dutka, Marcin	Poland	2012-2014	M	Hydrogen Combustion

#### POST-DOC STUDENTS WITH FINANCIAL SUPPORT FROM THE CENTRE BUDGET

<u>Name</u>	<u>Nationality</u>	<u>Period</u>	<u>Sex</u>	<u>Topic</u>
Zhang, Xiangping	China	2010-2013	F	CO <sub>2</sub> chain analyses.
Fu, Chao	China	2012-2014	M	Integrated Assessment
Kheradmand, Nousha	Iran	2012-2014	F	CO <sub>2</sub> Pipeline Integrity
Farokhpoor, Raheleh	Iran	2012-2014	F	Effects of CO <sub>2</sub> on Rock Properties

#### PH.D. STUDENTS WORKING IN CENTRE PROJECTS WITH FINANCIAL SUPPORT FROM OTHER SOURCES

<u>Name</u>	<u>Funding</u>	<u>Nationality</u>	<u>Period</u>	<u>Sex</u>	<u>Topic</u>
Vigen, Camilla	UiO	Norwegian	2009-2013	F	Novel mixed proton electron conductors for hydrogen gas separation membranes

#### PH.D. THESIS COMPLETED IN THE CENTRE SO FAR

Morin, Alexandre	France	2009-2013	M	Mathematical modeling and numerical simulation of two-phase multi-component flows of CO <sub>2</sub> mixtures in pipes
------------------	--------	-----------	---	--

**POST-DOC PROJECTS COMPLETED IN THE CENTRE SO FAR**

Bhuiyan, Anwar	Bangladesh	2010-2013	M	Time-lapse CSEM sensitivity analysis for CO <sub>2</sub> sequestration
Karimaie, Hassan	Iran	2010-2013	M	Optimal design of CO <sub>2</sub> injection operation.

**BOARD MEMBERS 2012**

<b>Name</b>	<b>Company</b>	<b>Country</b>
Chadwick, Andy	British Geological Survey	UK
Lindefjeld, Ole	ConocoPhillips	Norway
Svendsen, Pål Tore	Hydro Aluminium	Norway
Teigland, Rune	TOTAL E&P	Norway
Mårdalen, Jostein	SINTEF Petroleum Research	Norway
<b>Røkke, Nils A. (Chair)</b>	<b>SINTEF Energy Research</b>	<b>Norway</b>
Berger, Bjørn	Statoil	Norway
Steinskog, Tom	GDF Sues	Norway
Svendsen, Hallvard	NTNU	Norway
Svendsen, Thorbjørn G.	Gassco AS	Norway

**GENERAL ASSEMBLY MEMBERS 2012**

<b>Name</b>	<b>Company</b>	<b>Country</b>
Berg Aasen, Tone Merethe	NTNU Samfunnsforskning AS	Norway
Britze, Peter	GEUS	Denmark
Bøe, Reidulv	NGU	Norway
Chadwick, Andy	British Geological Survey	UK
Eriksson, Kjell	Det Norske Veritas	Norway
Haarberg, Torstein	SINTEF	Norway
Kutne, Peter	DLR	Germany
Lindefjeld, Ole	ConocoPhillips	Norway
Lundegaard, Valborg	Aker Solutions ASA	Norway
Mårdalen, Jostein	SINTEF Petroleum Research	Norway
Nordby, Truls	University of Oslo	Norway
<b>Berger, Bjørn (Chair)</b>	<b>Statoil</b>	<b>Norway</b>
Røkke, Nils A.	SINTEF Energy Research	Norway
Sattelmayer, Thomas	Technische Universität München	Germany
Steinskog, Tom	GDF SUEZ	Norway
Svendsen, Hallvard	NTNU	Norway
Svendsen, Pål Tore	Hydro	Norway
Teigland, Rune	TOTAL E&P	Norway
Torvanger, Asbjørn	Cicero	Norway
Tweeddale, Adrian	Shell Technology Norway	Norway
Svendsen, Thorbjørn G	Gassco	Norway
Slagtern, Åse (observer)	Research Council of Norway	Norway



**SCIENTIFIC COMMITTEE MEMBERS 2012**

<b>Name</b>	<b>Company</b>	<b>Country</b>
Benson, Sally M.	Stanford University	USA
Hovorka, Susan D.	University of Texas at Austin	USA
<b>Hägg, May-Britt (Chair)</b>	<b>NTNU</b>	<b>Norway</b>
Kerstein, Alan	Sandia National Laboratories	USA
Rochelle, Gary T.	University of Texas at Austin	USA
Schiefloe, Per Morten	NTNU	Norway
Wessling, Mathias	University of Twente	Netherlands
Williams, Forman A.	Univ. of California at San Diego	USA

**EXPLOITATION AND INNOVATION ADVISORY COMMITTEE MEMBERS 2012**

<b>Name</b>	<b>Company</b>	<b>Country</b>
<b>Berger, Bjørn (Chair)</b>	<b>Statoil</b>	<b>Norway</b>
Langelandsvik, Leif I	Gassco	Norway
Saysset, Samuel	GDF SUEZ	France
Tweedale, Adrian	Shell Technology Norway	Norway

**A2. ACCOUNTING REPORT**

Costs are composed of cash and in-kind contributions. All figures in NOK.

<b>ACTUAL COSTS</b>	
Personnel and indirect costs	9 438 926
Purchases of R&D services	40 059 144
Equipment	103 731
Other operating costs	1 732 931
<b>Total</b>	<b>51 334 732</b>
<b>FUNDING</b>	
Own funding	13 270 044
Private funding	18 064 688
Research Council of Norway	20 000 000
<b>Total</b>	<b>51 334 732</b>

**A3. PUBLICATIONS****BOOK SECTIONS**

1. Anantharaman, R., et al., Design of an IRCC with CO<sub>2</sub> capture using a mixed integer optimization method, in *Computer Aided Chemical Engineering*. 2012. p. 52-55.
2. Torvanger, A., Carbon capture and storage, regulatory framework, in *Encyclopedia of Environmetrics, Second Edition*. 2012.

**CONFERENCE PAPERS**

3. Anantharaman, R. and D. Berstad, Energy Integration in an NGCC power plant with post-combustion CO<sub>2</sub> capture, in *PRES 2012*. 2012: Prague, Czech Republic.
4. Anantharaman, R., et al., Design of an IRCC with CO<sub>2</sub> capture utilizing a mixed integer optimization method (incl. poster), in *ESCAPE-22*. 2012: London, UK.
5. Anantharaman, R., K. Jordal, and T. Gundersen, CO<sub>2</sub> capture processes: Novel approach to benchmarking and evaluation of improvement potentials, in *The 11<sup>th</sup> Int'l Conference on Greenhouse Gas Control Technologies (GHGT-11)*. 2012: Kyoto, Japan.
6. Anantharaman, R., et al., Selection of optimal CO<sub>2</sub> capture plant capacity for better investment decisions (Poster), in *The 11<sup>th</sup> Int'l Conference on Greenhouse Gas Control Technologies (GHGT-11)*. 2012: Kyoto, Japan.
7. Anthonsen, K.L., et al., BIGCCS storage site webGIS, in *BIGCCS Consortium Day 2012*. 2012: Trondheim, Norway.
8. Aronu, U.A., et al., Understanding precipitation in amino acid salt systems at process conditions, in *The 11<sup>th</sup> Int'l Conference on Greenhouse Gas Control Technologies (GHGT-11)*. 2012: Kyoto, Japan.
9. Arstad, B., et al., Studies of Ca-based high temperature sorbents for CO<sub>2</sub> capture, in *The 11<sup>th</sup> Int'l Conference on Greenhouse Gas Control Technologies (GHGT-11)*. 2012: Kyoto, Japan.
10. Aursand, E., et al., CO<sub>2</sub> pipeline integrity: A coupled fluid-structure model using a reference equation of state for CO<sub>2</sub>, in *The 11<sup>th</sup> Int'l Conference on Greenhouse Gas Technologies (GHGT-11)*. 2012: Kyoto, Japan.
11. Aursand, P., et al., Coupled fluid-structure simulation of running fracture in CO<sub>2</sub> pipelines, in *The Third International Forum on the Transportation of CO<sub>2</sub> by Pipeline*. 2012: Newcastle, UK.
12. Berstad, D., R. Anantharaman, and P. Nekså, Low-temperature CCS from an IGCC power plant and comparison with physical solvents, in *The 11<sup>th</sup> Int'l Conference on Greenhouse Gas Control Technologies (GHGT-11)*. 2012: Kyoto, Japan.
13. Cerasi, P., Investigation of geomechanical and rock physics aspects related to underground storage and monitoring of CO<sub>2</sub>, in *International Conference on CO<sub>2</sub> Injection for EOR & Geological Sequestration*. 2012, CSIR-National Geophysical Research Institutes: Hyderabad, India.
14. Chen, X., M.-A. Einarsrud, and T. Grande, Fabrication of dense La<sub>2</sub>NiO<sub>4+ $\delta$</sub>  membranes by water-based tape casting and mechanical properties, in *The 12<sup>th</sup> International Conference on Inorganic Membranes*. 2012: Enschede, Netherlands.

15. Chen, X., et al., Anisotropic Thermal and Chemical Expansion of Rhombohedral Perovskites, in *The 12<sup>th</sup> International Conference on Inorganic Membranes*. 2012: Enschede, Netherlands.
16. Ditaranto, M., R. Anantharaman, and T. Weydahl, Performance and NO<sub>x</sub> emissions of refinery fired heaters retrofitted to hydrogen combustion, in *The 11<sup>th</sup> Int'l Conference on Greenhouse Gas Control Technologies (GHGT-11)*. 2012: Kyoto, Japan.
17. Ditaranto, M., et al., Effect of long pulse duration on time resolved pulse duration, in *The 4<sup>th</sup> LII workshop*. 2012: Le Touquet, France.
18. Ditaranto, M., I. Saanum, and M. Seljeskog, Radiative properties and soot formation in oxy-fuel atmospheres, in *IFRF 17<sup>th</sup> International Member Conference*. 2012.
19. Einaasen, N., et al., A numerical solution strategy for dynamic simulation of post-combustion CO<sub>2</sub> capture, in *The 11<sup>th</sup> Int'l Conference on Greenhouse Gas Control Technologies (GHGT-11)*. 2012: Kyoto, Japan.
20. Einaasen, N., et al., Dynamic behavior of the solvent regeneration part of a CO<sub>2</sub> capture plant, in *The 11<sup>th</sup> Int'l Conference on Greenhouse Gas Control Technologies (GHGT-11)*. 2012: Kyoto, Japan.
21. Fontaine, M.-L., et al., Development of thin film tubular membranes and investigation of transport properties (Invited keynote lecture), in *International Conference on Inorganic Membranes (ICIM)*. 2012: Amsterdam, Netherlands.
22. Fontaine, M.-L., et al., CO<sub>2</sub> removal at high temperature from multi-component gas stream using porous ceramic membranes infiltrated with molten carbonates, in *The 11<sup>th</sup> Int'l Conference on Greenhouse Gas Control Technologies (GHGT-11)*. 2012: Kyoto, Japan.
23. Frykman, P., Geology and the effects on filling pattern in CO<sub>2</sub> storage sites, in *The 74<sup>th</sup> EAGE Conference & Exhibition incorporating SPE EUROPEC 2012*. 2012: Copenhagen, Denmark.
24. Frykman, P., C.M. Nielsen, and N. Bech, Trapping effects of small scale sedimentary heterogeneities, in *The 11<sup>th</sup> Int'l Conference on Greenhouse Gas Control Technologies (GHGT-11)*. 2012: Kyoto, Japan.
25. Grimstad, A.-A., Modelling in BIGCCS, in *CO2GeoNet Open Forum 2012*. 2012: Venice Italy.
26. Grude, S., M. Landrø, and B. Osdal, Time lapse pressure-saturation discrimination for CO<sub>2</sub> storage at the Snøhvit Field, in *SEG Annual Meeting 2012*. 2012: Las Vegas, USA.
27. Henriksen, P.P., Progress and achievements of Task 1.2, in *BIGCCS Capture Day*. 2012: Oslo, Norway.
28. Hoff, K.A. and H.F. Svendsen, CO<sub>2</sub> absorption with membrane contactors vs. packed absorbers - Challenges and opportunities in post combustion capture and natural gas sweetening, in *The 11<sup>th</sup> Int'l Conference on Greenhouse Gas Control Technologies (GHGT-11)*. 2012: Kyoto, Japan.
29. Håkonsen, S.F., C.A. Grande, and R. Blom, Rotating bed reactor for CLC; bed characteristics dependencies on internal gas mixing, in *The 2<sup>nd</sup> International Conference on Chemical Looping* 2012: Darmstadt, Germany.
30. Jakobsen, J.P., et al., A standardized approach to the assessment of CCS projects (Poster), in *The 11<sup>th</sup> Int'l Conference on Greenhouse Gas Control Technologies (GHGT-11)*. 2012: Kyoto, Japan.
31. Johannessen, B., T. Løvås, and A. Gruber, Numerical studies of laminar and turbulent flame speed for premixed hydrogen-air flames, in *The 34<sup>th</sup> International Combustion Symposium 2012*: Warsaw, Poland.

32. Kolla, H., et al., Turbulent flux of mixture fraction in inert and reactive transverse jet in cross-flow, in *The 34<sup>th</sup> International Combustion Symposium 2012*: Warsaw, Poland.
33. Li, H., et al., Optimization of cryogenic CO<sub>2</sub> purification for oxy-coal combustion, in *The 11<sup>th</sup> Int'l Conference on Greenhouse Gas Control Technologies (GHGT-11)*. 2012: Kyoto, Japan.
34. Lindeberg, E. and H. Karimaie, Experimental verification of CO<sub>2</sub> dissolution rate due to diffusion induced convection, in *The 11<sup>th</sup> Int'l Conference on Greenhouse Gas Control Technologies (GHGT-11)*. 2012: Kyoto, Japan.
35. Løvseth, S.W., et al., CO<sub>2</sub>Mix Project: Experimental determination of thermo-physical properties of CO<sub>2</sub>-rich mixtures, in *The 11<sup>th</sup> Int'l Conference on Greenhouse Gas Control Technologies (GHGT-11)*. 2012: Kyoto, Japan.
36. Ma, X., R. Beck, and J.-P. Andreassen, Crystal growth kinetics of potassium bicarbonate in water, in *BIWIC*. 2012: Tiajin, China.
37. Ma'mun, S. and I. Kim, Selection and characterization of phase-change solvent for carbon dioxide capture: precipitating system, in *The 11<sup>th</sup> Int'l Conference on Greenhouse Gas Control Technologies (GHGT-11)*. 2012: Kyoto, Japan.
38. Møltnvik, M.J., R. Aarli, and N.A. Røkke, BIGCCS Centre - Supporting large-scale CCS implementation, in *The 11<sup>th</sup> Int'l Conference on Greenhouse Gas Control Technologies (GHGT-11)*. 2012: Kyoto, Japan.
39. Nielsen, C.M., P. Frykman, and F. Dalhoff, Synergy benefits in combining CCS and geothermal energy production, in *The 11<sup>th</sup> Int'l Conference on Greenhouse Gas Control Technologies (GHGT-11)*. 2012: Kyoto, Japan.
40. North, A., Stability and liftoff of a nitrogen diluted hydrogen jet flame in a vitiated co-flow under gas turbine conditions, in *The 34<sup>th</sup> International Combustion Symposium 2012*: Warsaw, Poland.
41. Noy, D.J., et al., Modelling large-scale carbon dioxide injection into the Bunter Sandstone in the UK Southern North Sea, in *The 11<sup>th</sup> Int'l Conference on Greenhouse Gas Control Technologies (GHGT-11)*. 2012: Kyoto, Japan.
42. Rasmussen, R., Time lapse seismic monitoring of individually thin layered reservoir subunits for CO<sub>2</sub> storage, in *The 74<sup>th</sup> EAGE Conference & Exhibition incorporating SPE EUROPEC 2012*. 2012: Copenhagen, Denmark.
43. Romano, M.C., et al., Application of advanced technologies for CO<sub>2</sub> capture from industrial sources, in *The 11<sup>th</sup> Int'l Conference on Greenhouse Gas Control Technologies (GHGT-11)*. 2012: Kyoto, Japan.
44. Romdhane, A., C. Ravaut, and E. Querendez, CO<sub>2</sub> monitoring at the Sleipner Field with full waveform inversion, in *EGU general assembly 2012*. 2012: Vienna, Austria. p. 13054.
45. Roussanaly, S., et al., Multi-criteria analysis of two CO<sub>2</sub> transport technologies (Poster), in *The 11<sup>th</sup> Int'l Conference on Greenhouse Gas Control Technologies (GHGT-11)*. 2012: Kyoto, Japan.
46. Roussanaly, S., et al., Integrated techno-economic and environmental assessment of an amine-based capture for different CO<sub>2</sub> concentration gases, in *The 11<sup>th</sup> Int'l Conference on Greenhouse Gas Control Technologies (GHGT-11)*. 2012: Kyoto, Japan.
47. Roussanaly, S., et al., Joint techno-economic and environmental benchmark of an amine-based capture for different CO<sub>2</sub> concentration gases (Poster), in *Technoport 2012*. 2012: Trondheim, Norway.

48. Roussanaly, S., J.P. Jakobsen, and E.S. Hognes, Integrated techno-economic and environmental benchmark of two CO<sub>2</sub> transport technologies, in *European Project COCATE Workshop*. 2012: Johannesburg, South Africa.
49. Salimath, P., et al., Study of entropy generation of H<sub>2</sub>-air combustion in 1-D plane laminar and 3-D turbulent v-shaped flame channel flow configuration using (S3D) Direct Numerical Simulation, in *The 34<sup>th</sup> International Combustion Symposium 2012*: Warsaw, Poland.
50. Sánchez, R., et al., An investigation of the heat integration between the two riser units constituting a circulation fluidized bed reactor for the SE-SMR process, in *The 11<sup>th</sup> Int'l Conference on Greenhouse Gas Control Technologies (GHGT-11)*. 2012: Kyoto, Japan.
51. Sanchez, R.A., et al., One dimensional two-fluid model simulations of the SE-SMR process operated in a circulating fluidized bed reactor, in *The 20<sup>th</sup> International Congress of Chemical and Process Engineering CHISA*. 2012: Prague, Czech Republic.
52. Sanchez, R.A. and H.A. Jakobsen, Simulation of sorption-enhanced steam methane reforming and chemical looping reforming in a circulating fluidized bed reactor, in *Ninth International Conference on CFD in the Minerals and Process Industries, CSIRO*. 2012: Melbourne, Australia.
53. Schäfer, M., et al., An apparatus for the gravimetric preparation of gas mixtures, in *Thermodynamik-Kolloquium*. 2012: Potsdam, Germany.
54. Seljeskog, M., A. Sevault, and M. Ditaranto, Pursuing the oxy-fuel light-/heavy oil retrofit route in oil refineries - A small scale retrofit study, in *The 11<sup>th</sup> Int'l Conference on Greenhouse Gas Control Technologies (GHGT-11)*. 2012: Kyoto, Japan.
55. Soroush, M., L. Høier, and J. Kleppe, CO<sub>2</sub> injection and CO<sub>2</sub> WAG in dipping gas condensate and oil reservoirs, in *The 18<sup>th</sup> SPE Improved Oil Recovery Symposium (SPE 154062)*. 2012: Tulsa Oklahoma, USA.
56. Soroush, M., et al., Affecting parameters in density driven convection mixing in CO<sub>2</sub> storage in brine, in *SPE EUROPEC 2012 (SPE 154901)*. 2012: Copenhagen, Denmark.
57. Stang, H.G.J., et al., Accurate measurements of CO<sub>2</sub>-rich mixture phase equilibria relevant for CCS transport and conditioning, in *The 11<sup>th</sup> Int'l Conference on Greenhouse Gas Control Technologies (GHGT-11)*. 2012: Kyoto, Japan.
58. Sæther, O.M., et al., Mineralogical characterization of three North Sea sandstone formations considered for storage of CO<sub>2</sub>, in *AGU Fall Meeting*. 2012: San Francisco, CA, USA.
59. Taheri, A., et al., Experimental and simulation studies of density-driven-convection mixing in hallow geometry with application for CO<sub>2</sub> sequestration in brine aquifers, in *SPE EUROPEC 2012 (SPE 154908)*. 2012: Copenhagen, Denmark.
60. Taheri, A., et al., The effects of anisotropy and heterogeneity on CO<sub>2</sub> dissolution in deep saline aquifers, in *Carbon Management Technology Conference*. 2012: Orlando, Florida, USA.
61. Taheri, A., D. Wessel-Berg, and O. Torsæter, Simulation study of density-driven natural convection mechanism in isotropic and anisotropic brine aquifers using a black oil reservoir simulator, in *The 11<sup>th</sup> Int'l Conference on Greenhouse Gas Control Technologies (GHGT-11)*. 2012: Kyoto, Japan.
62. Taheri, A., et al., The gravitational instability of a diffusive boundary layer; towards a theoretical minimum for time of onset of convection, in *Carbon Management Technology Conference*. 2012: Orlando, FL, USA.

63. Weibull, W., B. Arntsen, and E.B. Raknes, *Initial velocity models for full waveform inversion*, in *SEG AM Conference*. 2012: Las Vegas, USA.
64. Weydahl, T., P. Salimath, and A. Gruber, *Fundamental modelling of a membrane reactor with in situ hydrogen separation and combustion*, in *The 11<sup>th</sup> Int'l Conference on Greenhouse Gas Control Technologies (GHGT-11)*. 2012: Kyoto, Japan.
65. Weydahl, T., P. Salimath, and A. Gruber, *Head-on quenching on a H<sub>2</sub> transport membrane wall*, in *The 11<sup>th</sup> Int'l Conference on Greenhouse Gas Control Technologies (GHGT-11)*. 2012: Kyoto, Japan.
66. White, J.C., G.A. Williams, and R.A. Chadwick, *Thin layer detectability in a growing CO<sub>2</sub> plume: testing the limits of time-lapse seismic resolution*, in *The 11<sup>th</sup> Int'l Conference on Greenhouse Gas Control Technologies (GHGT-11)*. 2012: Kyoto, Japan.
67. Williams, J.D.O. and S. Holloway, *The capability of faults and top seals in the Bunter sandstone of the UK Southern North Sea to seal carbon dioxide*, in *The 3<sup>rd</sup> International conference on Fault and Top Seals - from characterization to modelling*. 2012: Montpellier, France.
68. Zhang, X., X. He, and T. Gundersen, *Assessment and analysis of post-combustion carbon capture with membrane separation technology*, in *AIChE Annual Meeting*. 2012: Pittsburgh, USA

### **JOURNAL ARTICLES**

69. Aasen, T.M.B., et al., *Innovation in a heterogeneous CCS research centre, managerial and organizational challenges*, in *Energy Procedia*, 2012. **23**(2012): p. 296-305.
70. Anantharaman, R. and D. Berstad, *Energy integration in an NGCC plant with post-combustion CO<sub>2</sub> capture – systematic methodology for evaluating process alternatives*, in *Chemical Engineering Transaction*, 2012. **29**: p. 451-456.
71. Arstad, B., J. Probst, and R. Blom, *Continuous hydrogen production by sorption enhanced steam methane reforming (SE-SMR) in a circulating fluidized bed reactor: Sorbent to catalyst ratio dependencies*, in *Chemical Engineering Journal*, 2012. **189-190**: p. 413-421.
72. Berstad, D., R. Anantharaman, and K. Jordal, *Post-combustion CO<sub>2</sub> capture from a natural gas combined cycle by CaO/CaCO<sub>3</sub> looping*, in *Int'l Journal of Greenhouse Gas Control*, 2012. **11**: p. 25-33.
73. Bhuiyan, A.H., M. Landrø, and S.E. Johansen, *Three-dimensional CSEM modelling and time-lapse sensitivity analysis for subsurface CO<sub>2</sub> storage*, in *Geophysics*, 2012. **77**(5): p. E343-E355.
74. Bischi, A., et al., *Hydrodynamic viability of chemical looping processes by means of cold flow model investigation*, in *Applied Energy*, 2012. **97**(2012): p. 201-216.
75. Chadwick, R.A., et al., *Measuring pressure performance of a large saline aquifer during industrial-scale CO<sub>2</sub> injection: The Utsira Sand, Norwegian North Sea*, in *Int'l Journal of Greenhouse Gas Control*, 2012. **10**(0): p. 374-388.
76. Chikukwa, A., et al., *Dynamic modeling of post-combustion CO<sub>2</sub> capture using amines - A review*, in *Energy Procedia*, 2012. **23**(2012): p. 82-91.
77. Eichler, C., G. Baumgartner, and T. Sattelmayer, *Experimental investigation of turbulent boundary layer flashback limits for premixed hydrogen-air flames confined in ducts*, in *Journal of Engineering for Gas Turbines and Power*, 2012. **134**(1).

78. Giljarhus, K.E.T., S.T. Munkejord, and G. Skaugen, Solution of the Span–Wagner equation of state using a density–energy state function for fluid-dynamic simulation of carbon dioxide, in *Industrial & Engineering Chemistry Research*, 2012. **51(2)**(2012): p. 1006-1014.
79. Grout, R.W., et al., A direct numerical simulation study of turbulence and flame structure in transverse jets analysed in jet-trajectory based coordinates, in *Journal of Fluid Mechanics*, 2012. **706**: p. 351-383.
80. Gruber, A., et al., Direct numerical simulation of premixed flame boundary layer flashback in turbulent channel flow, in *Journal of Fluid Mechanics*, 2012. **709**: p. 516-542.
81. Grude, S., B. Osdal, and M. Landrø, Sea-bed diffractions and their impact on 4D seismic data, in *Geophysical Prospecting*, 2012. **1**(16).
82. Husebye, J., et al., Techno economic evaluation of amine based CO<sub>2</sub> capture: Impact of CO<sub>2</sub> concentration and steam supply, in *Energy Procedia*, 2012. **23**(2012): p. 381-390.
83. Kim, I., X. Ma, and J.-P. Andreassen, Study of the solid-liquid solubility in the piperazine H<sub>2</sub>O-CO<sub>2</sub> system using FBRM and PVM, in *Energy Procedia*, 2012. **23**(2012): p. 72-81.
84. Kim, I., et al., Solubility measurements of piperazine, in *Energy Procedia*, 2012. **Vol 23**.
85. Larring, Y., et al., Investigation of La<sub>0.87</sub>Sr<sub>0.13</sub>CrO<sub>3-δ</sub> as membrane for hydrogen production, in *Membranes*, 2012. **2**: p. 665-686.
86. Li, H., M. Ditaranto, and J. Yan, Carbon capture with low energy penalty: Supplementary fired natural gas combined cycles, in *Applied Energy*, 2012. **97**: p. 164-169.
87. Ma, X., et al., Precipitation of piperazine in aqueous piperazine solutions with and without CO<sub>2</sub> loadings, in *Industrial & Engineering Chemistry Research*, 2012. **51**(37): p. 12126-12134.
88. Morin, A., T. Flåtten, and S.T. Munkejord, A Roe Scheme for a Compressible Six-Equation Two-Fluid Model, in *Int'l Journal for Numerical Methods in Fluids*, 2012: p. 1-28.
89. Morin, A., S. Kragset, and S.T. Munkejord, Pipeline flow modelling with source terms due to leakage: The straw method original research article, in *Energy Procedia*, 2012. **23**(2012): p. 226-235.
90. Nielsen, C.M. and P. Frykman, Regional model development and study of pressure propagation, in *Energy Procedia*, 2012. **23**(2012): p. 495-503.
91. Nordhagen, H.O., et al., A new coupled fluid–structure modeling methodology for running ductile fracture, in *Computers & Structures*, 2012. **94-95**: p. 13-21.
92. Noy, D.J., et al., Modelling large-scale carbon dioxide injection into the Bunter Sandstone in the UK Southern North Sea, in *International Journal of Greenhouse Gas Control*, 2012. **9**(0): p. 220-233.
93. Røkke, N.A., The 6<sup>th</sup> Trondheim conference on CO<sub>2</sub> capture, transport and storage (editorial), in *Energy Procedia*, 2012. **23 (2012)**: p. 1-2.
94. Røyrvik, J., M. Schei Olsen, and T.M.B. Aasen, Political rationality and CCS discourse, in *Energy Procedia*, 2012. **23**(2012): p. 284-295.
95. Soundararajan, R. and T. Gundersen, Coal based power plants using oxy-combustion for CO<sub>2</sub> capture: Pressurized coal combustion to reduce capture cost penalty, in *Chemical Engineering Transactions*, 2012. **29**: p. 187-192.



96. Vigen, C.K., T.S. Bjørheim, and R. Haugsrud, *The role of B-site cations on proton conductivity in double Perovskite oxides  $\text{La}_2\text{MgTiO}_6$  and  $\text{La}_2\text{MgZrO}_6$* , in *International Journal of Hydrogen Energy*, 2012. **37**(9).
97. Williams, G. and R. Chadwick, *Quantitative seismic analysis of thin layer  $\text{CO}_2$  in the Sleipner injection plume*, in *Geophysics*, November 2012, 77(6), pp. R245-R256.
98. Ystad, P.A.M., O. Bolland, and M. Hillestad, *NGCC and hard-coal power plant with  $\text{CO}_2$  capture based on absorption*, in *Energy Procedia*, 2012. **23**(2012): p. 33-44.

#### **MAGAZINE AND NEWSPAPER ARTICLES**

99. Aasen, T.M.B., *Forskning for et grønnere samfunn*, in *Forskning nr. 1/2012*. 2012.
100. Stensvold, T., *SINTEF sikrer forsker-ess*, in *Teknisk Ukeblad*. 2012. p. 61.

#### **REPORTS**

101. Aarlien, R., *Annual Report 2011: BIGCCS Centre - International CCS Research Centre*. 2012, SINTEF Energy Research: Trondheim, Norway. April 2012. p. 44.

**CONTACT INFORMATION**

Web:	<a href="http://www.bigccs.no">www.bigccs.no</a>
Postal address	SINTEF Energy Research PO Box 4761 Sluppen NO-7465 Trondheim
Chairman of the Board	Mr. Nils A. Røkke E-mail: <a href="mailto:Nils.A.Rokke@sintef.no">Nils.A.Rokke@sintef.no</a> Telephone: +47-73 59 25 14
Centre Director	Ms. Mona J. Mølsvik E-mail: <a href="mailto:Mona.J.Molnsvik@sintef.no">Mona.J.Molnsvik@sintef.no</a> Telephone: +47-73 59 29 75
Centre Manager	Mr. Rune Aarlién E-mail: <a href="mailto:Rune.Aarlién@sintef.no">Rune.Aarlién@sintef.no</a> Telephone: +47-73 59 39 29
Operations Manager	Mr. Jon Magne Johansen E-mail: <a href="mailto:JonMagne.Johansen@sintef.no">JonMagne.Johansen@sintef.no</a> Telephone: +47-73 59 39 57
Leader SP1	Mr. Rune Bredesen E-mail: <a href="mailto:Rune.Bredesen@sintef.no">Rune.Bredesen@sintef.no</a> Telephone: +47-938 11 279
Leader SP2	Mr. Svend Tollak Munkejord E-mail: <a href="mailto:Svend.T.Munkejord@sintef.no">Svend.T.Munkejord@sintef.no</a> Telephone: +47-73 59 38 97
Leader SP3	Ms. Grethe Tangen E-mail: <a href="mailto:Grethe.Tangen@sintef.no">Grethe.Tangen@sintef.no</a> Telephone: +47-73 59 13 29
Leader SP4	Ms. Amy Brunsvold E-mail: <a href="mailto:Amy.Brunsvold@sintef.no">Amy.Brunsvold@sintef.no</a> Telephone: +47-73 59 39 55
Leader SP5	Mr. Truls Gundersen E-mail: <a href="mailto:truls.gundersen@ntnu.no">truls.gundersen@ntnu.no</a> Telephone: +47-73 59 37 21



BIGCCS animation movie – QR:



BIGCCS – future technology with a greener footprint...

## BIGCCS Partners

### Research Institutes:

- BGS - Natural Environment Research Council
- CICERO Center for International Climate and Environmental Research
- Deutsche Zentrum für Luft- und Raumfahrt
- GEUS - Geological Survey of Denmark and Greenland
- Geological Survey of Norway
- NTNU Social Research AS
- SINTEF Petroleum Research
- SINTEF Energy Research (Host Institution)
- SINTEF Foundation

### Universities:

- Norwegian University of Science and Technology
- University of Oslo
- TU München by Lehrstuhl Für Thermodynamik

### Industry:

- Aker Solutions AS
- ConocoPhillips Skandinavia AS
- Det Norske Veritas AS
- Gassco AS
- GDF SUEZ
- Hydro Aluminium AS
- Shell Technology Norway AS
- Statoil Petroleum AS
- TOTAL E&P Norge AS



## The CEER Scheme

The Centres for Environment-friendly Energy Research (CEER) scheme is an initiative to establish time-limited research centres conducting concentrated, focused, and long-term research of high international calibre in order to solve specific challenges in the field of energy and environment. The centres were selected early 2009 via a detailed review process administered by the Research Council of Norway.

Two main assessment criteria formed the basis for the selection of the CEERs: relevance and potential for innovation and value creation, and scientific merit. One prerequisite for achieving the status of CEER is that the centres consist of a distinct combination of researchers, research institutions, organizations, industry and private enterprises. The CEERs receive NOK 10-20 million annually from the Research Council of Norway for five years, with a possibility for a three year extension.

The CEER scheme is a direct follow-up of the broad-based political agreement on climate change policy adopted by the Norwegian Parliament in 2008, and of the national R&D strategy Energy21 of that same year.

More information about the CEER scheme can be found at:  
[www.forskningsradet.no/energiserter](http://www.forskningsradet.no/energiserter)



BIGCCS International CCS Research Centre  
[www.BIGCCS.no](http://www.BIGCCS.no)