

Automation: Control, Responsibility, Authority, and Trustworthiness

Bryant Walker Smith

Assistant Professor

University of South Carolina School of Law
and (by courtesy) School of Engineering

Affiliate Scholar

Center for Internet and Society at Stanford Law School

Codirector

Program on Law and Mobility at University of Michigan Law School

law of the
newly
Possible
newlypossible.org

Upshot

Language is important

Law is important

Trustworthiness is essential

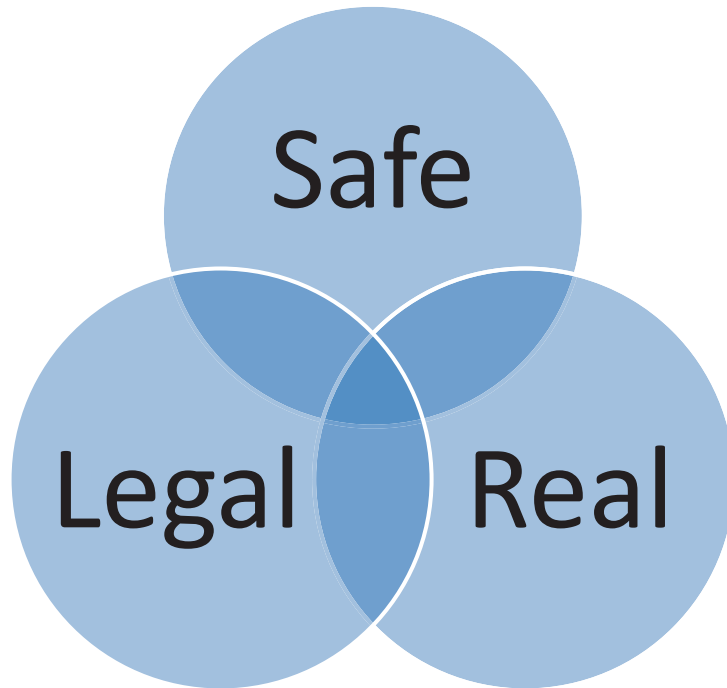

law of the
newly
Possible
newlypossible.org



law of the
newly
Possible
newlypossible.org



[uspsig.gov/document/autonomous-vehicles-postal-service](https://www.uspsig.gov/document/autonomous-vehicles-postal-service)

law of the
newly
Possible
[newlypossible.org](https://www.newlypossible.org)

~~“Control”~~

law of the
newly
Possible
[newlypossible.org](https://www.newlypossible.org)

“Drivers shall at all times be able to control their vehicles”

1949 Vienna Convention on Road Traffic; cf. 1968 Geneva Convention on Road Traffic

law of the
newly
Possible
newlypossible.org

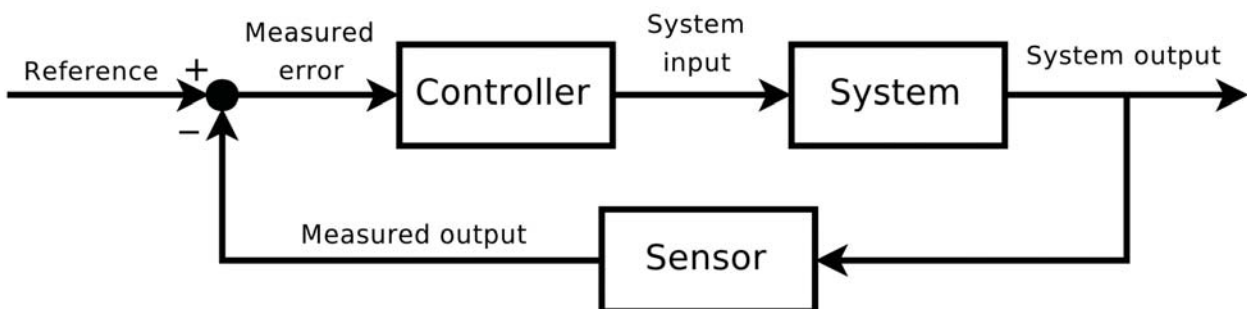



[flickr.com/photos/dumbledad/3225255407](https://www.flickr.com/photos/dumbledad/3225255407)

law of the
newly
Possible
newlypossible.org

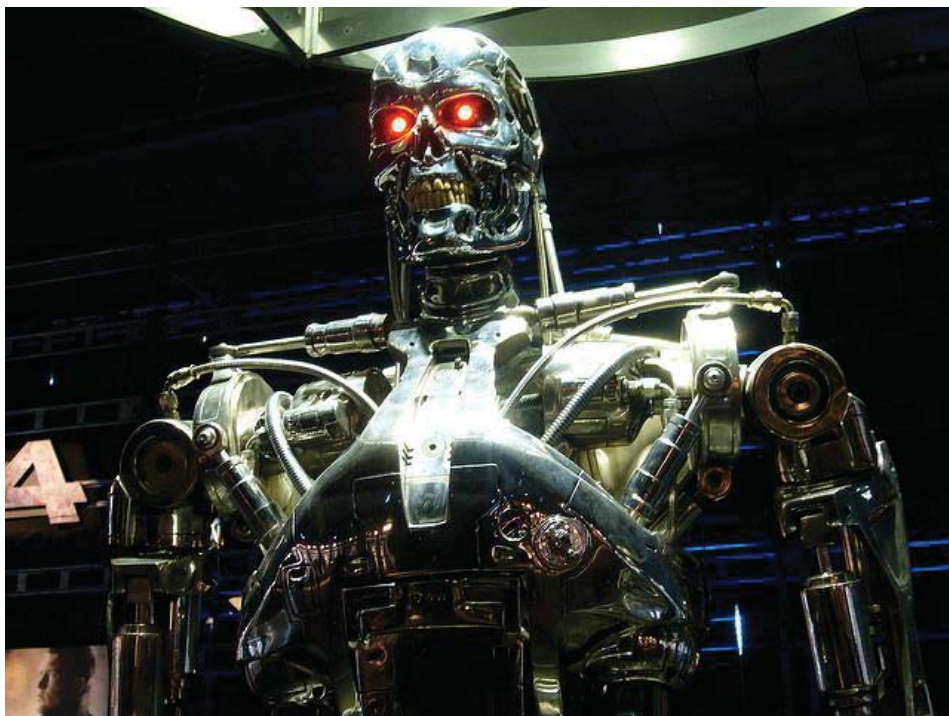

[flickr.com/photos/31029865@N06/14997552775](https://www.flickr.com/photos/31029865@N06/14997552775)

law of the
newly
Possible
newlypossible.org



SURFACE VEHICLE RECOMMENDED PRACTICE	J3016™	JUN2018
	Issued 2014-01 Revised 2018-06	
	Superseding J3016 SEP2016	
(R) Taxonomy and Definitions for Terms Related to Driving Automation Systems for On-Road Motor Vehicles		

sae.org/standards/content/j3016_201806/

law of the
newly
Possible
newlypossible.org

“Control”

“Perform the dynamic driving task”

law of the
newly
Possible
newlypossible.org

“Responsibility”

Types of responsibility

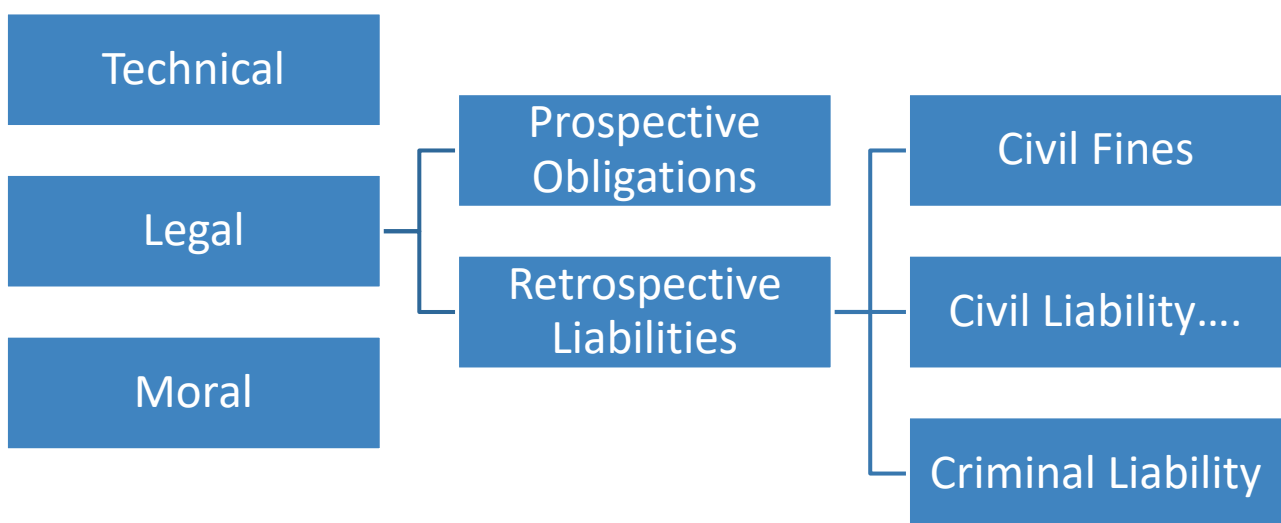

Technical roles



SAE J3016™ LEVELS OF DRIVING AUTOMATION

	SAE LEVEL 0	SAE LEVEL 1	SAE LEVEL 2	SAE LEVEL 3	SAE LEVEL 4	SAE LEVEL 5
What does the human in the driver's seat have to do?	You are driving whenever these driver support features are engaged – even if your feet are off the pedals and you are not steering			You are not driving when these automated driving features are engaged – even if you are seated in “the driver's seat”		
	You must constantly supervise these support features; you must steer, brake or accelerate as needed to maintain safety			When the feature requests, you must drive	These automated driving features will not require you to take over driving	
What do these features do?	These are driver support features			These are automated driving features		
	These features are limited to providing warnings and momentary assistance	These features provide steering OR brake/acceleration support to the driver	These features provide steering AND brake/acceleration support to the driver	These features can drive the vehicle under limited conditions and will not operate unless all required conditions are met	This feature can drive the vehicle under all conditions	
Example Features	<ul style="list-style-type: none"> • automatic emergency braking • blind spot warning • lane departure warning 	<ul style="list-style-type: none"> • lane centering OR • adaptive cruise control 	<ul style="list-style-type: none"> • lane centering AND • adaptive cruise control at the same time 	<ul style="list-style-type: none"> • traffic jam chauffeur 	<ul style="list-style-type: none"> • local driverless taxi • pedals/steering wheel may or may not be installed 	<ul style="list-style-type: none"> • same as level 4, but feature can drive everywhere in all conditions

sae.org/standards/content/j3016_201806/

law of the
newly
Possible
newlypossible.org

On reaching a crash site, an automated driving system (ADS)-equipped vehicle stops in its lane until someone at a monitoring center sketches a travel path. Using its sensors, it then follows this path.

1) Is this L3 or L4 automated driving?

2) Is there a remote driver?

law of the
newly
Possible
newlypossible.org

“Authority”

law of the
newly
Possible
newlypossible.org

Automatic brakes stopped Berlin truck during Christmas market attack

Ethiopian pilots fought the Boeing 737 MAX flight controls almost from takeoff

An automated driving system “may delay a user-requested disengagement” (SAE J3016)

Spurious Authority

Time

Expertise

Information

Framing

Reliance

Cf. T.B. Sheridan & W.L. Verplank, W. L., Human and computer control of undersea teleoperators (1978), dtic.mil/cgi-bin/GetTRDoc?AD=ADA057655

law of the
newly
Possible
newlypossible.org

~~“Trust”~~

law of the
newly
Possible
newlypossible.org

~~Trust~~

Experience

Marketing

Words versus actions

The fiction of 100%

law of the
newly
Possible
newlypossible.org

“Trustworthiness”

law of the
newly
Possible
newlypossible.org

~~“Do we trust this new technology?”~~

Are the companies developing and
deploying new technologies
worthy of our trust?

Bryant Walker Smith, *The Trustworthy Company* (forthcoming), newlypossible.org

law of the
newly
Possible
newlypossible.org

Individuals won't drive AVs

Computers won't drive AVs

Companies will drive AVs

Bryant Walker Smith, *The Trustworthy Company* (forthcoming), newlypossible.org

law of the
newly
Possible
newlypossible.org

Companies will drive AVs

AVs are only as safe as their companies

Companies are legal subjects that act through their human and machine agents

Companies can do right even after their technologies fail

Bryant Walker Smith, *The Trustworthy Company* (forthcoming), newlypossible.org

law of the
newly
Possible
newlypossible.org

A trustworthy corporate driver

Shares its safety philosophy

Makes a promise to the public

Keeps that promise

Bryant Walker Smith, *The Trustworthy Company* (forthcoming), newlypossible.org

law of the
newly
Possible
newlypossible.org

Safety philosophy

“This is what we’re doing

“This is why we think it’s reasonably safe

This is why you can believe us”

Bryant Walker Smith, *The Trustworthy Company* (forthcoming), newlypossible.org

law of the
newly
Possible
newlypossible.org

Promise to the public

“We market only what we
reasonably believe to be safe

“We will be candid about our
limitations and failures

“When we fail,
we will make it right”

Bryant Walker Smith, *The Trustworthy Company* (forthcoming), newlypossible.org

law of the
newly
Possible
newlypossible.org

Keeping that promise

Manage public expectations

Supervise the entire product lifecycle

Mitigate harms promptly, fully, and publicly

Bryant Walker Smith, *The Trustworthy Company* (forthcoming), newlypossible.org

law of the
newly
Possible
newlypossible.org

A trustworthy company

Shares its safety philosophy

Makes a promise to the public

Keeps that promise

Bryant Walker Smith, *The Trustworthy Company* (forthcoming), newlypossible.org

law of the
newly
Possible
newlypossible.org

Companies will drive AVs

A promise to the public
(SAE J0316 Levels of Driving Automation)

“Automated driving provider”
(US Uniform Law Commission Automated Operation of Vehicles Act)

“Automated driving system entity”
(UK Law Commissions and Australia National Transport Commission)

law of the
newly
Possible
newlypossible.org

AUTOMATED OPERATION OF VEHICLES ACT

NATIONAL CONFERENCE OF COMMISSIONERS

ON UNIFORM STATE LAWS

Automated driving provider

Self-identifies to the state government

Represents that the automated vehicle is capable of complying with the vehicle code

Acts as the legal driver from the start of automated operation until a human driver intentionally terminates that operation

law of the
newly
Possible
newlypossible.org

More complex alternatives

“Level 3 fallback ready user (FBRU)”

(SAE J0316 Levels of Driving Automation)

“Remote driver”

(SAE J3016 Levels of Driving Automation)

“User-in-charge”

(UK Law Commissions and Australia National Transport Commission)

law of the
newly
Possible
newlypossible.org

Keep it simple

Either you are intentionally driving...

...or you are not driving

Because when everyone is responsible,
no one is responsible.

law of the
newly
Possible
newlypossible.org



law of the
newly
Possible
newlypossible.org

law of the
newly
Possible
newlypossible.org