

# Design of an Experimental ORC Expander Setup Using Natural Working Fluids

Ángel Á. Pardiñas\*, Marcin Pilarczyk, Roberto Agromayor, and Lars O. Nord

NTNU - The Norwegian University of Science and Technology  
Department of Energy and Process Engineering  
Trondheim, Norway

\* Corresponding Author: angel.a.pardinas@ntnu.no

## ABSTRACT

Organic Rankine Cycles (ORC) are an efficient and cost-effective technology to generate power from waste heat. Arguably, the two most important factors affecting the performance of the Rankine cycle are the choice of working fluid and the type of expander. This potential for waste heat recovery, combined with future restrictions on some working fluids, justify the need for further research on ORC expanders using natural fluids. To the knowledge of the authors, there is no experimental data available in the open literature for flows involving natural working fluids and operating conditions representative of ORC turbines. As a result, the fluid dynamic design methodologies used for ORC turbomachinery rely on tools that have not been validated. In response to this lack of experimental data, a test rig to characterize the performance of expanders in the 25–100 kW power capacity range using natural working fluids and their mixtures will be designed and built at NTNU. This unit, officially named EXPAND, is a part of the infrastructure project HighEFF-Lab, sponsored by The Research Council of Norway. The unit was designed to operate in the gas phase to reduce the heating and cooling needs as well as the charge of working fluid. The expander architecture selected for the first experimental campaign is a variable-speed, single-stage, axial turbine operating with isobutane (R600a).

## 1. INTRODUCTION

As a result of the growth of population and the economy, the energy use worldwide increases year after year. In parallel, the concerns about energy security and the environmental impact fossil fuel combustion rise within most of the developed countries. In this context, waste heat recovery is an effective means to improve energy efficiency and reduce CO<sub>2</sub> emissions. Papapetrou et al. (2018) examined the industrial waste heat in the EU by industrial sector and temperature level (in the range 100–1000°C) and concluded that there is a waste heat recovery potential of 300 TWh (thermal) per year and that one-third of this corresponds to the temperature level below 200°C. A similar study by Campana et al. (2013) focused on the cement, glass, steel and oil & gas industries and estimated that the waste heat recovery potential for 27 EU countries was 21.6 TWh of electricity production with saving of 7.6 Mtons of CO<sub>2</sub> emissions per year.

Organic Rankine Cycles (ORC) are an efficient and cost-effective technology to recover waste heat. The power capacity of these systems ranges from tens of kilowatts to a few megawatts and they can be used to produce power from low-temperature heat sources in the 100–350°C range (Colonna et al., 2015). Arguably, the two most important factors affecting the performance of the Rankine cycle are the choice of working fluid and type of expander. The selection of the working fluid is usually based on the thermodynamic or techno-economic optimization of the system but it also takes into account other factors such as the availability, flammability, toxicity, and environmental impact of the fluid (Macchi and Astolfi, 2017). As a result of environmental concerns and regulations (such as EU regulation 517/2014), the use of natural working fluids<sup>1</sup>

---

<sup>1</sup>Substances naturally-occurring in the environment, such as water, ammonia, CO<sub>2</sub>, and hydrocarbons.

for refrigeration and power systems has gained a lot of attention due to their negligible ozone depletion potential (ODP) and global warming potential (GWP).

The design of the expander has a great influence on the performance of the Rankine cycle because it converts the thermal energy of the working fluid into work. The design of an expander for a ORC power system is a challenging task because the flow conditions are often transonic or supersonic and the expansion occurs in thermodynamic regions with real gas effects, close to the critical point or to the vapor saturation curve. In addition, there is a lack of experimental data concerning fluids and flow conditions encountered in ORC turbines and, as a result, all the performance estimation and fluid dynamic design methodologies rely on tools that have not been validated for ORC applications (Head et al., 2016; Reinker et al., 2017). Table 1 contains a survey of experimental studies of ORC setups with different expanders. Most of the research activities were oriented towards small-capacity volumetric machines (especially screw and scroll expanders) using synthetic refrigerants that will be phased-out, and only a few works considered axial or radial turbines. In addition, the studies summarized in Table 1 aimed to analyze the performance of the ORC power system and the experimental data were not used to validate the existing fluid dynamic design methods or to develop new expander models.

In response to the lack of experimental data concerning ORC expanders using natural working fluids, a new test rig, officially named EXPAND, will be designed and built at NTNU as part of the infrastructure project HighEFF-Lab. The purpose of EXPAND is to characterize the performance of turbines and volumetric machines in the 25–100 kW power capacity range using natural working fluids and their mixtures. The goal of this paper is to present the preliminary design of the EXPAND setup, including the identification of that system requirements and selection of the working fluid and operation conditions for the first experimental campaign.

**Table 1:** Summary of selected experimental studies of ORC with various expanders.

Reference	Type	Fluid	$T_{in}$ [°C]	$PR$ [-]	$\dot{W}_{max}$ [kW]	$\eta_{max}$ [%]
Riffat and Zhao (2004)	Axial	n-pentane	105	5.0	3.7	n.a
Klonowicz et al. (2014) <sup>a</sup>	Axial	R227ea	58	2.4	10.1	59.0
Fu et al. (2015)	Axial	R245fa	119	5.7	225.0	63.7
Pu et al. (2016)	Axial	R245fa	n.a	3.0 – 3.5	2.0	59.7
Pei et al. (2011)	Radial	R123	93 – 100	7.0 – 7.5	3.3	66.0
Sung and Kim (2017)	Radial	R245fa	142 – 143	7.6 – 10.9	195.5	75.4
Kaczmarczyk et al. (2017) <sup>b</sup>	Radial	HFE7100	180	3.7 – 4.8	3.0	52.0
Bianchi et al. (2017)	Piston	R134a	65 – 85	1.8 – 2.7	1.2	42.0
Dumont et al. (2018)	Piston	R245fa	118 – 153	6.2 – 10.6	2.7	56.0
Dumont et al. (2018)	Roots	R245fa	70 – 124	1.1 – 4.5	3.1	43.0
Hsieh et al. (2017)	Screw	R218	90 – 100	1.9 – 2.5	19.7	57.0
Dumont et al. (2018)	Screw	R245fa	75 – 130	1.9 – 4.2	1.3	68.0
Lei et al. (2016)	Screw	R123	n.a	4.5 – 8.5	8.4	73.0
Yang et al. (2017)	Scroll	R245fa	n.a	n.a	1.9	79.0
Wu et al. (2015)	Scroll	R123	100 – 250	n.a	2.2	86.0
Chang et al. (2014)	Scroll	R245fa	81 – 86	n.a	1.8	68.4
Dumont et al. (2018)	Scroll	R245fa	122 – 133	1.4 – 7.4	1.5	68.0
Li et al. (2018)	Scroll	R123	100 – 140	1.5 – 12.0	0.6	n.a.
Miao et al. (2017)	Scroll	R123	150	6.0 – 13.0	2.7	70.0
Quoilin et al. (2010)	Scroll	R123	101 – 163	2.7 – 5.4	1.8	68.0

<sup>a</sup> Single-stage impulse turbine with 11% partial admission in the first stator.

<sup>b</sup> Four-stage radial inflow-outflow turbine with partial admission in the first stator.

## 2. EXPERIMENTAL SETUP DESIGN

This section describes the main characteristics of the EXPAND experimental setup. It begins with the presentation of the requirements considered to design the system and the description of the main loop of the experimental setup. Then, the selection of the working fluid is analyzed in a systematic way and, finally, the main components of the EXPAND test rig, namely the expander, compressors and heat exchangers are discussed.

### 2.1 System requirements and concept

As defined in Reinker et al. (2017), experimental setups for investigations related to fluid flows and thermodynamics can be classified into intermittent mode facilities and continuously running mode facilities. Intermittent flow systems consist of at least two reservoirs, one intended for high-pressure fluid and another for low-pressure fluid, and connected by a valve or diaphragm. The reservoirs are charged and evacuated, respectively, and the connecting device is opened rapidly, forcing the flow from one reservoir to the other during a limited time that depends on the size of the tanks. Continuously running mode facilities are conceived for longer tests, potentially at steady state, and using compressors, pumps and valves to ensure the working fluid circulation between the different pressure levels. EXPAND, the experimental setup described in the present article, falls into this second group of systems.

The purpose of EXPAND is to characterize the performance of expanders for ORC power systems operating with natural working fluids and their mixtures. More specifically, EXPAND was designed aiming at electrical power outputs in the range between 25 and 100 kW and expander inlet temperatures up to 150°C. These conditions correspond to mini-to-small power capacity and low-to-medium temperature ORC power systems according to the classification proposed in Colonna et al. (2015). The maximum pressure was limited to 20 bar to use conventional components and instrumentation. The minimum pressure was constrained above atmospheric to prevent air from leaking into the working fluid loop, which could degrade the performance and form a potentially flammable air-fluid mixture. In addition, the system was designed to operate in the gas phase region to minimize the working fluid charge and the heating and cooling duties associated with evaporation and condensation processes, respectively. Finally, flexibility in terms of operation conditions was carefully considered to allow for tests in a wide range of inlet temperature and pressure, pressure ratio, mass flow rate, and angular speed.

The process diagram of EXPAND is shown in Figure 1. The system operates following a Brayton cycle (gas phase). The pump used typically in ORC power systems is substituted by compressors. In addition, three plate heat exchangers are included to attain the target temperatures at the inlet of expander and compressors. Heat is rejected to an auxiliary cooling loop in the Cooler, is absorbed from an auxiliary heating loop in the Heater or recuperated from the low-pressure fluid to the high-pressure fluid in the Recuperator. In addition, a suction accumulator acts as a working fluid buffer and allows to adjust the working fluid charge in the main loop according to the needs of each test. Further details about these components are included in the next subsections.

### 2.2 Working fluid selection

Historically, many ORC power systems have used synthetic substances that have a negative impact on the environment due to their ODP or GWP once disposed or leaked during operation (Forster et al., 2007). Natural working fluids, on the other hand, have negligible or zero ODP and GWP, which is essential to reduce the environmental impact of future energy systems.

From the perspective of design, there are several characteristics that the working fluid should meet. It should be possible to operate within the minimum and maximum pressure limits and cover a wide range of pressure ratios (for instance, from 2 to 10). In addition, the saturation

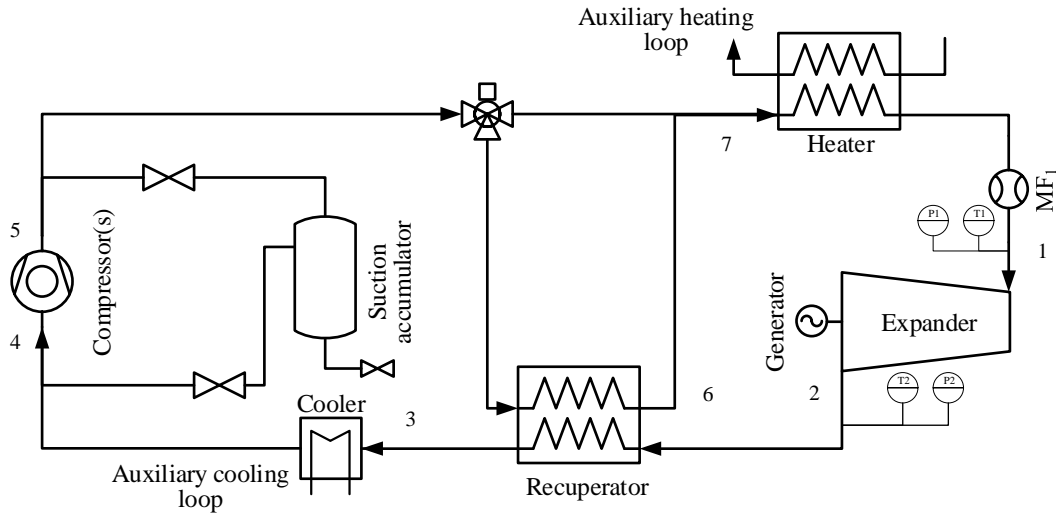

**Figure 1:** Process flow diagram of the EXPAND test rig.

temperatures at the inlet and outlet of the expander should approximately fall within the range from 15 °C to 150 °C so that the expanders tested would be representative in ORC systems using a low-to-medium temperature heat sources and air or sea-water as heat sink. Moreover, it was decided to use a pure substance, and not a mixture, to facilitate the commissioning of the test rig and the first experimental campaigns.

These constraints can be illustrated in a temperature-pressure diagram (Figure 2). This graph shows the saturation pressure of several pure natural working fluids as a function of temperature. Figure 2 was used to evaluate the suitability of these fluids, with the following conclusions:

- The saturation lines of the hydrocarbons analyzed, from propane to hexane, fall within the feasible region limited by the minimum and maximum temperatures and pressures.
- The saturation pressure of propane at 15 °C is already 7.3 bar, limiting the range of expander pressure ratios that respect the 20 bar maximum pressure.
- Isobutane is attractive because its saturation pressure at 15 °C is around 2 bar and, therefore, the range of pressure ratios respecting the 20 bar constraint is broad.
- Butane, pentane, and hexane could be used, but it would be necessary to increase the condensation temperature above 15 °C to fulfill superatmospheric operation.
- Aromatic hydrocarbons (e.g. benzene and toluene) require too high condensation temperatures to operate above atmospheric pressure.
- Water and ammonia meet the constraints within a very limited operation range. In addition, ammonia is toxic, and requires specific compatible materials.
- CO<sub>2</sub> is unsuitable because its saturation line is outside the feasible operation region. The system would have to be specifically designed for higher pressures if using CO<sub>2</sub>.

As concluded from the previous analysis, isobutane (R600a) is the fluid that best suits the pressure and temperature requirements and it is highlighted in blue in Figure 2. In addition, Figure 3 shows the  $T$ - $s$  diagram of isobutane when the expander inlet temperature is 150 °C and it illustrates the wide range of pressure ratios that respect the pressure constraints.

From a practical point of view, isobutane is commonly used in refrigeration applications and it is commercially available with high quality (low moisture) from gas suppliers. However, isobutane is a flammable hydrocarbon and it was necessary to consider actions to minimize the risk, such as charge minimization, early detection in case of leakage or continuous ventilation of the enclosure around the circuits containing the working fluid. More specifically, the system was designed to conform with the relevant EU directives: 2014/34/EC (ATEX directive),

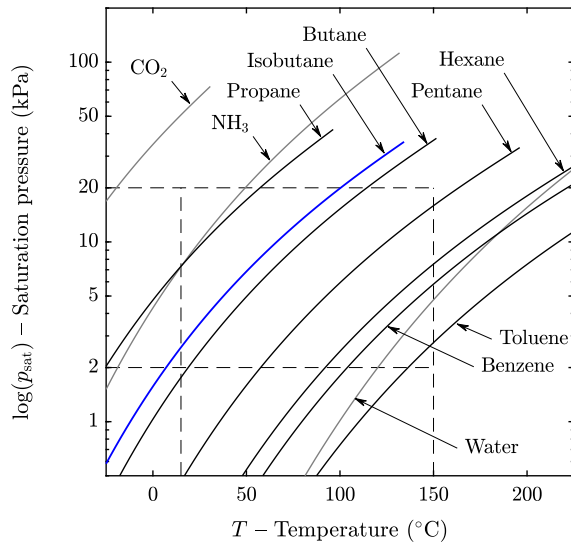

**Figure 2:** Saturation pressure and temperature of several natural working fluids and feasible operation region of the test rig.

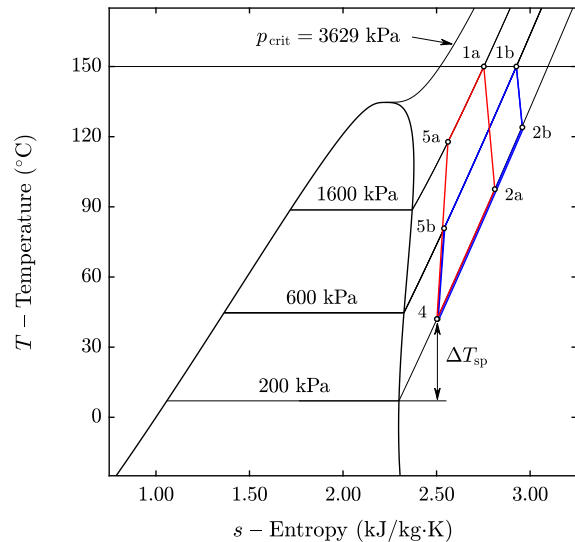

**Figure 3:**  $T$ - $s$  diagram of the test rig for the case of isobutane operating with a pressure ratio of 3 (b) and with a pressure ratio of 8 (a)

2006/42/EC (machinery directive), 2014/68/EC (pressure equipment directive), 2006/95/EC (electrical equipment designed for use within certain voltage limits).

### 2.3 Expander

EXPAND was designed to test both dynamic and volumetric expanders under design and off-design conditions. The first expander implemented is a single-stage axial turbine manufactured by ENOGIA. One of the advantages of this expander is that it is possible to replace the stator or rotor blades while keeping most of the other parts, such as the casing, ports and electrical generator. In order to operate the expander at different rotational speeds, the electrical generator was connected to a frequency converter that can supply the power generated from the expander to the compressors, reducing the amount of power exchanged with the grid.

The performance of the expander is assessed measuring the mass flow rate, thermodynamic states at the inlet and outlet, angular speed, and electrical power output. The acquisition system is based on a National Instruments cRIO and uses the following sensors and transducers:

- Coriolis mass flow meter for the determination of the working fluid mass flow through the expander, PROMASS F300 from Endress+Hauser AG.
- Pressure transducers for the absolute pressure at the expander inlet and outlet, Cerabar PMC71 from Endress+Hauser AG. Installed in the flow so that it is possible to measure either the stagnation pressure (through a Pitot tube) or the static pressure at each station.
- Temperature sensors for the stagnation temperature at the expander inlet and outlet, Omnigrad TR10 from Endress+Hauser AG (class A Pt100).
- Angular speed and electrical power output are measured from the frequency converter, A1000 converter from Omron.

### 2.4 Compressor

The pressure of the working fluid leaving the expander is lifted with a compressor instead of a pump (gas phase operation). Turbocompressors were adopted because they are more compact, light and silent than volumetric machines, and they do not need oil for their operation. Oil management is particularly challenging because even with efficient separation technologies, some oil would mix with the working fluid and compromise the turbine.

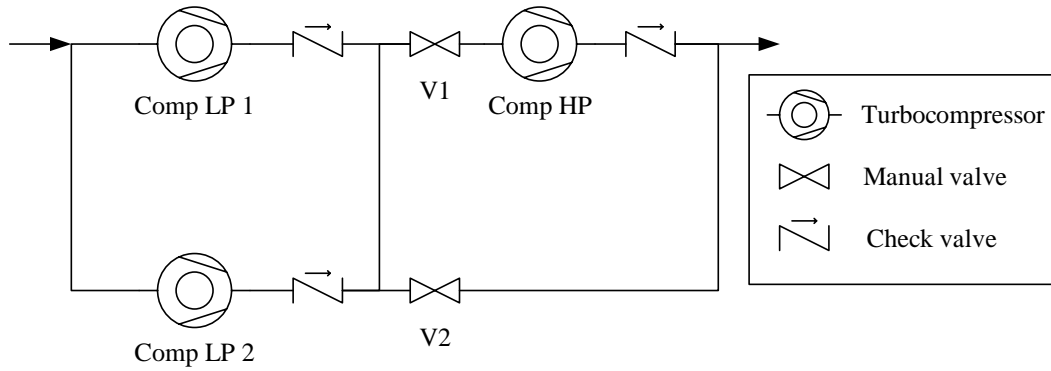

**Figure 4:** Turbocompressor arrangement used in EXPAND. In the low pressure lift–high mass flow rate configuration Comp LP1 and Comp LP2 are ON and the combined mass flow bypasses Comp HP (V1 is closed and V2 is open). In the high pressure lift–low mass flow rate configuration either Comp LP1 or Comp LP2 is ON and the pressure ratio is further increased by Comp HP (V1 is open and V2 is closed).

The main disadvantage of turbocompressors is their relatively low flexibility to deliver different pressure ratios and mass flow rates. This issue was solved by implementing several turbocompressors in series and parallel as shown in Figure 4.

## 2.5 Heat Exchangers

The target temperatures at the inlet of the expander and the set of compressors is achieved controlling the heat supplied at the Heater and rejected at the Cooler. In addition, the Recuperator was installed because, depending on the operation conditions, it is possible to recover heat from the the fluid leaving the expander and reduce the heating and cooling needs. Plate heat exchangers were adopted for Heater, Cooler and Recuperator to increase the compactness of the system with respect to other heat exchanger geometries.

The recuperation potential is illustrated in the  $T$ – $s$  diagram of Figure 3. It can be observed that there is no potential for recuperation when the pressure ratio is high (red cycle) but that, when the pressure ratio is sufficiently low, it is possible to recover heat from the fluid leaving the turbine (blue cycle). Steady-state simulations for different operating conditions and working fluids were performed to evaluate the convenience of installing the Recuperator. The model assumed constant isentropic efficiencies for expander and compressor and fixed heat transfer coefficients and pressure drops for the heat exchangers. The results of these simulations for the case of isobutane (R600a) are shown in Table 2.

It can be observed that the recuperation potential  $\dot{Q}_{\text{rec}}$  increases as the expander inlet temperature increases and the pressure ratio decreases. For the best case (case number 3), the recuperator would allow to reduce the external heating-cooling needs by 180 kW, which is higher than the heat flow rate exchanged in the heater or the cooler. It can also be observed that in some cases (case number 4, 7 and 8) there is no recuperation potential,  $\dot{Q}_{\text{rec}} < 0$ , because the expander inlet temperature is low and the pressure ratio is high. In these cases the recuperator should be by-passed using a three-way valve, see Figure 1.

## 3. CONCLUSIONS

The design of a continuously running mode experimental setup to test dynamic and volumetric expanders using natural working fluids was described. The system was designed for expander power outputs in the range of 25–100 kW and expander inlet temperatures below 150°C. In addition, a systematic selection of working fluid and components, namely expander, compressors and heat exchangers was performed. The main conclusions from this study are:

**Table 2:** Simulations performed to evaluate the convenience of implementing the recuperator.

Case	$PR_{\text{turb}}$ [-]	$p_{\text{turb, in}}$ [bar]	$p_{\text{turb, out}}$ [bar]	$T_{\text{turb, in}}$ [°C]	$\dot{m}_{\text{turb}}$ [kg/s]	$\dot{W}_{\text{turb}}$ [kW]	$\dot{W}_{\text{comp}}$ [kW]	$\dot{Q}_{\text{heater}}$ [kW]	$\dot{Q}_{\text{cooler}}$ [kW]	$\dot{Q}_{\text{rec}}$ [kW]
1				100	1.60	44.3	94.2	76.6	126.5	60.0
2	2	4	2	125	1.60	47.7	94.2	102.4	148.9	119.1
3				150	1.60	51.1	94.3	129.9	173.1	180.7
4				100	0.85	44.3	72.2	55.3	83.3	-15.2
5	4	8	2	125	0.85	48.2	72.3	68.0	92.0	18.8
6				150	0.85	52.0	72.3	81.2	101.5	53.9
7				100	0.70	44.8	74.7	56.6	86.5	-46.9
8	6	12	2	125	0.70	49.3	74.7	65.3	90.6	-15.6
9				150	0.70	53.5	74.7	76.1	97.2	14.5

- The system was designed to operate only in the gas phase to reduce the heating and cooling duties as well as the charge of working fluid.
- The working fluid selected for the first test campaign is isobutane (R600a) because it allows to operate over a broad range of pressure ratios within the pressure constraints.
- The expander architecture selected for the first experimental campaign is a single-stage, axial turbine coupled to a frequency converter that allows operation at variable speed.
- The data obtained will be valuable to validate the numerical models used in the design of expanders for low-temperature power cycles.

## ACKNOWLEDGEMENT

This publication has been partly funded by HighEFF - Centre for an Energy Efficient and Competitive Industry for the Future, an 8-year Research Centre under the FME-scheme (Centre for Environment-friendly Energy Research, 257632). The authors gratefully acknowledge the financial support from the Research Council of Norway and user partners of HighEFF.

## REFERENCES

- Bianchi, M., Branchini, L., Pascale, A. D., Orlandini, V., Ottaviano, S., Pinelli, M., Spina, P., and Suman, A. (2017). Experimental Performance of a Micro-ORC Energy System for Low Grade Heat Recovery. *Energy Procedia*, 129:899 – 906.
- Campana, F., Bianchi, M., Branchini, L., De Pascale, A., Peretto, A., Baresi, M., Fermi, A., Rossetti, N., and Vescovo, R. (2013). ORC waste heat recovery in European energy intensive industries: Energy and GHG savings. *Energy Conversion and Management*, 76:244–252.
- Chang, J.-C., Chang, C.-W., Hung, T.-C., Lin, J.-R., and Huang, K.-C. (2014). Experimental Study and CFD Approach for Scroll Type Expander Used in Low-Temperature Organic Rankine Cycle. *Applied Thermal Engineering*, 73(2):1444 – 1452.
- Colonna, P., Casati, E., Trapp, C., Mathijssen, T., Larjola, J., Turunen-Saaresti, T., and Uusitalo, A. (2015). Organic Rankine Cycle Power Systems: From the Concept to Current Technology, Applications, and an Outlook to the Future. *Journal of Engineering for Gas Turbines and Power*, 137(10):1–19.
- Dumont, O., Parthoens, A., Dickes, R., and Lemort, V. (2018). Experimental Investigation and Optimal Performance Assessment of Four Volumetric Expanders (Scroll, Screw, Piston and Roots) Tested in a Small-Scale Organic Rankine Cycle System. *Energy*, 165:1119 – 1127.
- Forster, P., Ramaswamy, V., Artaxo, P., Berntsen, T., Betts, R., Fahey, D. W., Haywood, J., Lean, J., Lowe, D. C., Myhre, G., Nganga, J., Prinn, R., Raga, G., Schultz, M., and

- Van Dorland, R. (2007). Climate Change 2007: The Physical Science Basis. Contribution of Working Group I to the Fourth Assessment Report of the IPCC.
- Fu, B.-R., Lee, Y.-R., and Hsieh, J.-C. (2015). Design, Construction, and Preliminary Results of a 250-kW Organic Rankine Cycle System. *Applied Thermal Engineering*, 80:339 – 346.
- Head, A. J., De Servi, C., Casati, E., Pini, M., and Colonna, P. (2016). Preliminary Design of the ORCHID: A Facility for Studying Non-Ideal Compressible Fluid Dynamics and Testing ORC Expanders. *ASME Turbo Expo 2016: Turbomach. Tech. Conf. and Exp.*, pages 1–14.
- Hsieh, J.-C., Fu, B.-R., Wang, T.-W., Cheng, Y., Lee, Y.-R., and Chang, J.-C. (2017). Design and Preliminary Results of a 20-kW Transcritical Organic Rankine Cycle with a Screw Expander for Low-Grade Waste Heat Recovery. *Applied Thermal Eng.*, 110:1120 – 1127.
- Kaczmarczyk, T., Zywicka, G., and Innatowicz, E. (2017). The Impact of Changes in the Geometry of a Radial Microturbine Stage on the Efficiency of the Micro CHP Plant Based on ORC. *Energy*, 137:530 – 543.
- Klonowicz, P., Borsukiewicz-Gozdur, A., Hanausek, P., Kryllowicz, W., and Bruggemann, D. (2014). Design and Performance Measurements of an Organic Vapour Turbine. *Applied Thermal Engineering*, 63(1):297 – 303.
- Lei, B., Wang, W., Wu, Y.-T., Ma, C.-F., Wang, J.-F., Zhang, L., Li, C., Zhao, Y.-K., and Zhi, R.-P. (2016). Development and Experimental Study on a Single Screw Expander Integrated into an Organic Rankine Cycle. *Energy*, 116:43 – 52.
- Li, J., Gao, G., Li, P., Pei, G., Huang, H., Su, Y., and Ji, J. (2018). Experimental Study of Organic Rankine Cycle in the Presence of Non-Condensable Gases. *Energy*, 142:739 – 753.
- Macchi, E. and Astolfi, M. (2017). *Organic Rankine Cycle (ORC) Power Systems: Technologies and Applications*. Woodhead Publishing, 1st edition.
- Miao, Z., Xu, J., and Zhang, K. (2017). Experimental and Modeling Investigation of an Organic Rankine Cycle System Based on the Scroll Expander. *Energy*, 134:35 – 49.
- Papapetrou, M., Kosmadakis, G., Cipollina, A., La Commare, U., and Micale, G. (2018). Industrial Waste Heat: Estimation of the Technically Available Resource in the EU per Industrial Sector, Temperature Level and Country. *Applied Thermal Eng.*, 138:207–216.
- Pei, G., Li, J., Li, Y., Wang, D., and Ji, J. (2011). Construction and Dynamic Test of a Small-Scale Organic Rankine Cycle. *Energy*, 36(5):3215 – 3223.
- Pu, W., Yue, C., Han, D., He, W., Liu, X., Zhang, Q., and Chen, Y. (2016). Experimental Study on ORC for Low Grade Thermal Energy Recovery. *App. Th. Eng.*, 94:221 – 227.
- Quoilin, S., Lemort, V., and Lebrun, J. (2010). Experimental Study and Modeling of an Organic Rankine Cycle Using Scroll Expander. *Applied Energy*, 87(4):1260 – 1268.
- Reinker, F., Kenig, E. Y., Passmann, M., and aus der Wiesche, S. (2017). Closed Loop Organic Wind Tunnel (CLOWT): Design, Components and Control System. *En. Proc.*, 129:200 – 207.
- Riffat, S. and Zhao, X. (2004). A Novel Hybrid Heat-Pipe Solar Collector/CHP System - Part II: Theoretical and Experimental Investigations. *Renewable Energy*, 29(12):1965 – 1990.
- Sung, T. and Kim, K. C. (2017). An Organic Rankine Cycle for Two Different Heat Sources: Steam and Hot Water. *Energy Procedia*, 129:883 – 890.
- Wu, Z., Pan, D., Gao, N., Zhu, T., and Xie, F. (2015). Experimental Testing and Numerical Simulation of Scroll Expander in a Small Scale Organic Rankine Cycle System. *Applied Thermal Engineering*, 87:529 – 537.
- Yang, S.-C., Hung, T.-C., Feng, Y.-Q., Wu, C.-J., Wong, K.-W., and Huang, K.-C. (2017). Experimental Investigation on a 3kW Organic Rankine Cycle for Low-Grade Waste Heat Under Different Operation Parameters. *Applied Thermal Engineering*, 113:756 – 764.