

FME HighEFF

Centre for an Energy Efficient and Competitive Industry for the Future



Deliverable D3.2_2019.01

Concept for low temperature plate freezing and energy storage for fish processing industry

Delivery date: 2020-01-07

Organisation name of lead partner for this deliverable:

SINTEF Ocean

<p>HighEFF- Centre for an Energy Efficient and Competitive Industry for the Future is one of Norway's Centre for Environment-friendly Energy Research (FME). Project co-funded by the Research Council of Norway and Industry partners. Host institution is SINTEF Energi AS.</p>		
--	--	--

Dissemination Level		
---------------------	--	--

PU	Public	X
RE	Restricted to a group specified by the consortium	
INT	Internal (restricted to consortium partners only)	

Deliverable number:	D3.2_2019.01
ISBN number:	-
Deliverable title:	Concept for low temperature plate freezing and energy storage for fish processing industry
Work package:	WP 3.2 HTHP, cooling, and drying
Deliverable type:	Report
Lead participant:	SINTEF Ocean

Quality Assurance, status of deliverable		
Action	Performed by	Date
Verified (WP leader)	Michael Bantle	06.01.2020
Reviewed (RA leader)	Trond Andresen	07.01.2020
Approved (dependent on nature of deliverable)*)	Trond Andresen	07.01.2020

*) *The quality assurance and approval of HighEFF deliverables and publications have to follow the established procedure. The procedure can be found in the HighEFF eRoom in the folder "Administrative > Procedures".*

Authors		
Author(s) Name	Organisation	E-mail address
Eirik Starheim Svendsen	SINTEF Ocean	eirik.starheim.svendsen@sintef.no

Abstract
<p>Large refrigeration demands are characteristic for fish processing plants, due to freezing and chilling equipment and maintaining room temperature in cold storages. Furthermore, there is a strong connection between production flow and power consumption, creating distinctive peaks at high-cost electricity hours. Cold thermal energy storage (CTES) introduces the possibility to decouple the link between refrigeration demand and supply, indicating a good fit for the food processing industry. This paper investigates the effects of CTES integration into a refrigeration system for a fish processing plant in order to reduce peak power consumption, by conducting a comparative energy analysis for the system with and without CTES. Main findings of this study were that integration of CTES led to a 46% reduction in peak power consumption at the cost of 4% extra energy consumption for a 24-hr period. It was assessed that this could induce significant savings on the overall electricity bill, dependent on rate structure.</p>

Table of Contents

1	Introduction.....	4
2	Theory.....	5
2.1	Thermal loads in industrialized food processing plants	5
2.2	Cold thermal energy storage (CTES).....	5
3	Method	7
3.1	Scenario	7
3.2	Refrigeration system	8
3.3	Energy calculations.....	9
4	Results and discussion	10
5	Conclusions and further work	12
6	References.....	13

1 Introduction

One of the most widely used methods for preserving food is accomplished by freezing, which slows down the rate of quality deterioration and prolongs shelf life. Once the food is frozen it can be stored for long periods, which allows for non-urgent long-distance distribution and creates the possibility for an even raw material supply throughout the seasons. This is particularly important for foodstuff which has a rapid spoilage rate, such as fish and other seafoods. In terms of carbon footprint, often the means of transport has a more significant contribution than the seafood processing itself [1]. Freezing of seafood introduces the possibility to shift a large share of the seafood export from air cargo to slow going container ships, and thus could reduce the greenhouse gas emissions stemming from the seafood sector. Increasing the degree of seafood processing before export would further elevate this potential, but for high-cost countries such as Norway this must be done in an energy efficient and cost-effective manner.

Automatization and robotization of manually intensive operations are important drivers that can lead to major savings for processing plants. Such plants must often employ complex energy systems to handle the variety of different thermal processes. Typical processes could be freezing, chilling and HVAC, but also hot processes such as pre-heating of washing water, drying etc. Designing an energy system that solves all these tasks in an energy efficient and climate friendly manner is necessary in order to further increase the profitability, with potential savings of both capital and operating expenses.

This paper investigates the potential effects of integrating cold thermal energy storage (CTES) into the refrigeration system of a fish processing plant. Objective is to reduce the peak electrical power consumption of the refrigeration system, which typically has a strong connection to the production flow (and thus thermal demand profile) for the plant. To achieve this, a CTES system with capacity to cover freezer equipment load is integrated into the refrigeration system, and allows for shifting of cold production from high- to low-cost (electricity) hours.

Keywords: low temperature, cold thermal energy storage, fish processing

2 Theory

2.1 Thermal loads in industrialized food processing plants

Processing of foodstuff often involves many thermal processes intended to make food safe for human consumption and extend its shelf life. In simple terms, bacteria are responsible for food spoilage and refrigeration is a widely used measure to reduce the bacterial activity in many types of foodstuff. The term food spoilage related to seafood does not only include harmful or life-threatening effects, but also non-harmful changes in appearance, taste or smell that is undesirable for the consumer.

The major share of energy consumption in fish processing plants can usually be attributed to the refrigeration system. This is due to the number of thermal processes occurring; freezing, chilling, drying etc., and also to maintain room temperature in cold storages – all of which are energy intensive tasks. In Norway, the processing of seafood is the largest energy consumer within the food industry with a total consumption of 1 207 GWh in 2018 [2]. Furthermore, the power consumption is typically linked to the production hours of the plant. This results in a distinctive peak in the power consumption during the time when processing equipment such as freezers, chillers etc. are running, as can be seen in Figure 1.

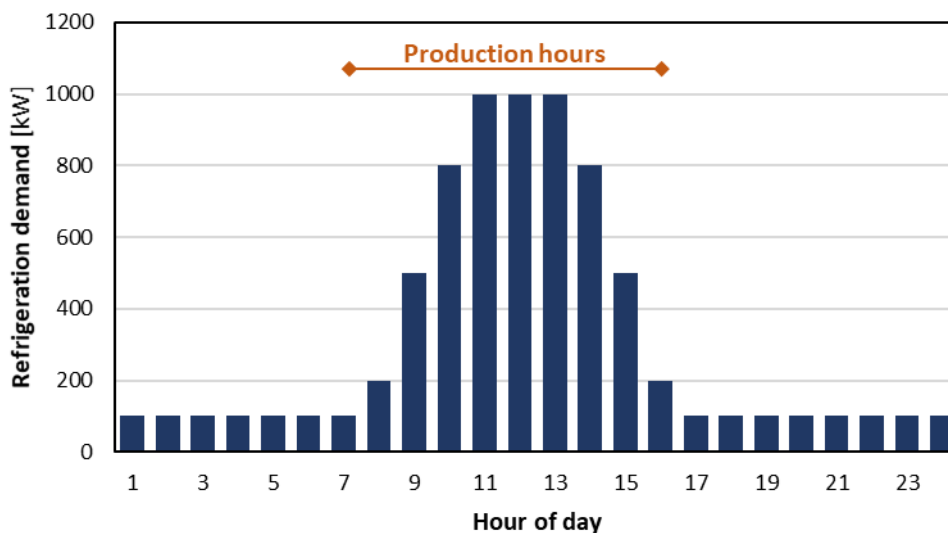

Figure 1: Example of a refrigeration demand curve throughout a 24-hr period for a food processing plant, illustrating a characteristic peak power consumption during production hours

The strong connection between power consumption and production flow has an economic consequence, as production hours typically coincide with the period of day when electricity rates are peaking. During non-production hours, typically at night, both consumption and electricity rates are low.

2.2 Cold thermal energy storage (CTES)

CTES is an interesting feature that can decouple the link between refrigeration demand and supply. The motivation for applying CTES in a fish processing plant can be understood by viewing Figure 1. A refrigeration demand peak corresponds to a power consumption peak, and this occurs during hours when the electricity rate usually is the highest. CTES, decoupling demand and supply, allows for transferring a share of the energy consumption to low-cost hours and thus reduce the electricity charge bill. In addition to this, the power consumption peak will be reduced which could further induce savings on reduced electricity demand charges (Norwegian: "nettleie"). For the Norwegian electricity rate structure, the latter has the most significant

potential in terms of reducing the overall cost related to electricity, as the demand charge usually is calculated as a function of peak power consumption.

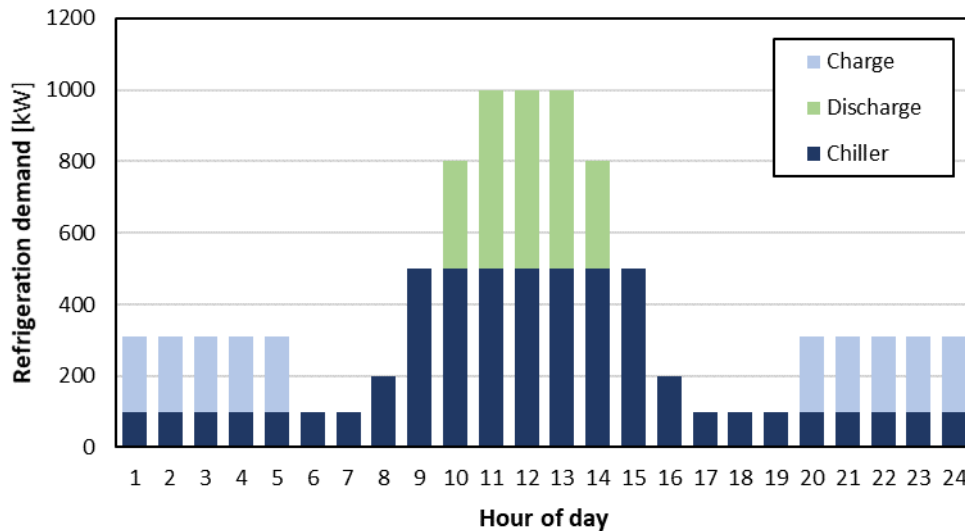

Figure 2: Share of refrigeration demand covered by chiller and an ideal CTES

Figure 2 illustrates the effect of integrating an ideal CTES into the energy system. The example plant has the same refrigeration demand as before, but during the peak hours between 10-14 a CTES assists the chiller, meaning that the power consumption will reduce proportionally during the same period. To charge the storage, chiller load during low-cost hours has increased, illustrated as light blue bars in the chart above.

What also can be seen from the chart is that the required chiller compressor capacity can be reduced, thereby reducing capital cost in the case of new facilities. For retrofitting CTES into an existing chiller system, this could be interpreted as a potential for increased overall plant capacity.

Other potential benefits could be

- Given that energy system COP is dependent on outside temperature, an increase in the energy efficiency can be improved when transferring a share of the cold production to night-time.
- Storages can act as backup cold supply in the case of power failures
- Offer better flexibility for system operation

The economic benefits of CTES must be weighed against the investment and operational costs involved, but such an analysis must account for several aspects, some difficult to quantify, and should thus be carried out on a case-by-case basis.

3 Method

To investigate the effects of CTES integration, a comparative energy study is performed on a concept refrigeration system with and without CTES. The CTES is dimensioned and designed to cover the refrigeration demand associated with freezer equipment. The same scenario is applied for both systems.

3.1 Scenario

Based on characteristic curves for food processing plants, a refrigeration demand profile for a 24-hour period has been created. The loads are divided into two temperature levels, medium temperature (chilling storages, chilled production areas) and low temperature (freezing storages and freezer equipment).

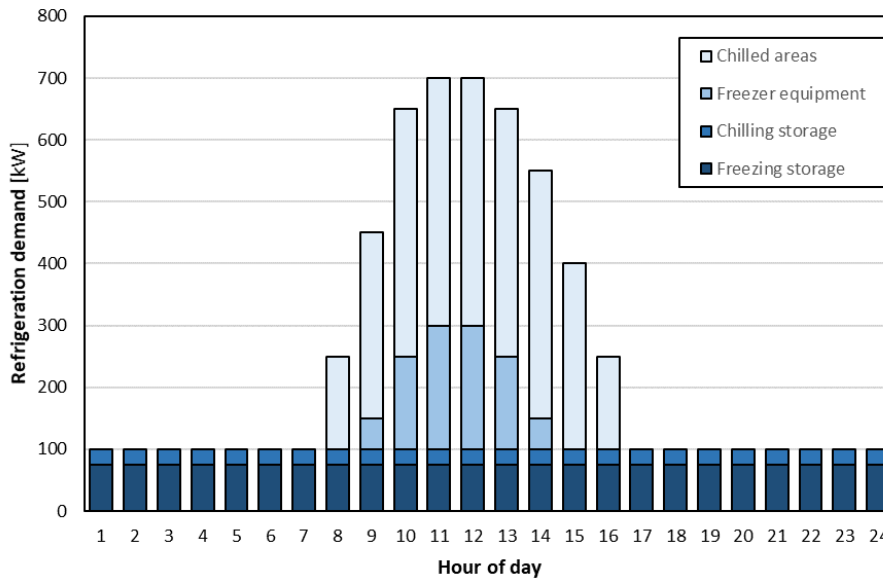

Figure 3: Refrigeration demand profile for this study

To highlight the possible benefits of increasing energy efficiency of the system by transferring a share of the energy usage to night-time, air coolers are employed in the refrigeration system to reject condensation heat. The following air temperatures are used as a basis for the 24-hour period, retrieved from [3] (18.07.2019, Orkdal station), emulating a typical summer day in Norway.

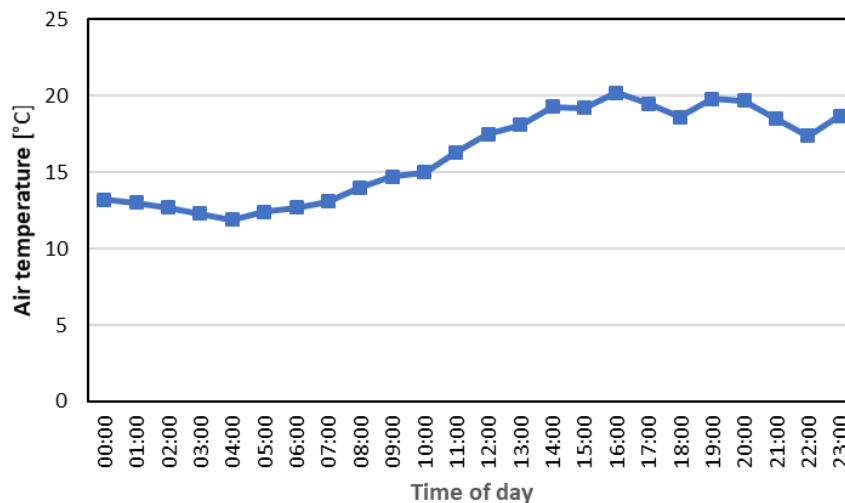

Figure 4: Air temperature profile for this study

3.2 Refrigeration system

A cascade refrigeration system is proposed, employing the natural refrigerants NH₃ and CO₂. The low temperature cycle (LTC), consisting of a compressor (LT), low-pressure receiver (LPR) and a flooded evaporator (LT-EV), cover all refrigeration demands for freezing equipment and freezing storages at -50 °C. In the simplified process and instrumentation diagram (P&ID) shown in Figure 5, these loads are lumped together and visualised in a single evaporator unit. The condensing heat from the LTC is transferred to the HTC by means of a cascade heat exchanger (CHX), where -10 °C NH₃ meets -5 °C CO₂. The NH₃ compressor (HT) further lifts and rejects this heat to the ambient air via an air cooler, while the circuit also serves the chilling loads (at -10 °C).

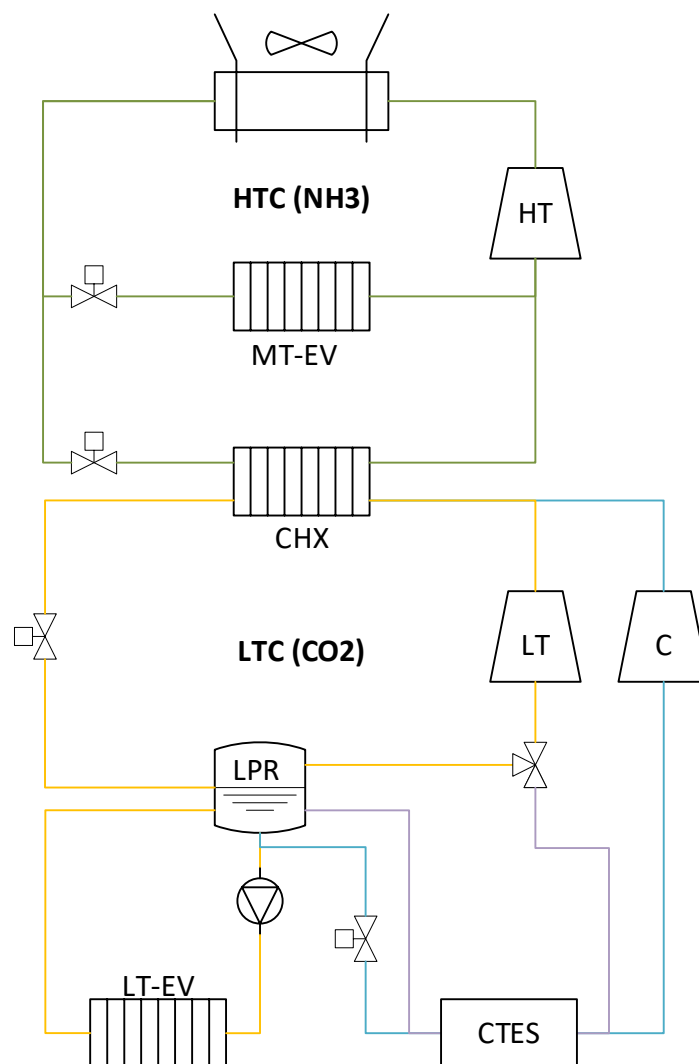

Figure 5: Refrigeration system concept with integrated CTES solution for the low temperature (freezing) cycle

In addition, a CTES unit is integrated in the LTC, denoted in the P&ID with blue (charging) and purple (discharging) lines. The CTES unit is a shell and tube vessel containing pressurized CO₂ on the shell side acting as phase change material (PCM), which has a melting enthalpy of approximately 205 kJ/kg and a phase change temperature (solid-liquid) at -57 °C. In order to charge the storage, liquid CO₂ from the LPR is expanded to even lower temperatures, meaning that the resulting flow is operating below the triple point of

CO₂. This gas-solid flow stream will flow through the tubes, extracting heat from the PCM which is then solidifying in the shell side. As this process occurs, the solid particles of the flow stream will sublimate, and the outlet stream is compressed via the charger compressor (C). This concept of CO₂ as PCM is further described and detailed in [4].

Discharging the CTES unit occurs whenever the LT compressor is not able to maintain correct suction pressure. A share of the vapour stream is then routed through and condensed in the CTES unit, which in turn melts the PCM. In essence this means that the energy storage is assisting the LT compressor with cold produced at other times. For this concept, there are three modes in which the CTES can operate; 1) charging, 2) idle and 3) discharging. The CTES storage is dimensioned to cover refrigeration load due to the freezer equipment, with a total capacity of 800 kWh.

3.3 Energy calculations

Only considering the electrical power needed to drive the compressors in the system, the following formulas are used to determine the energy usage of the refrigeration system. All calculations are carried out with MS Excel, used in combination with the open source thermodynamic library CoolProp [5]. Thermodynamic properties of CO₂ below the triple point is not covered by this software, and properties have been retrieved from literature. Calculations are carried out on an hourly basis covering a 24-hr period and assumes steady state behaviour in each interval. Changes in system occurs discretely between hours.

Electrical work to drive the compressors is determined using the formula:

$$\dot{W}_i = \dot{m}_i \cdot \Delta h_{\text{discharge-suction}}$$

Where i denotes LT, HT and C. The mass flow rates are dictated by refrigeration demands and energy balances, and compressors are assumed to work with a constant isentropic efficiency at 70%. Hourly power consumption for the system (compressors) is equal to:

$$\dot{W}_{\text{tot}} = \sum \dot{W}_i$$

Pressure levels are considered constant in the system, except for high pressure in the HTC circuit which is dependent on ambient temperature. Thermodynamic state properties for compressor suction points are considered as saturated vapor. Evaporation pressure in LTC is evaluated at -50 °C, condensation pressure at -5 °C. Evaporation pressure in HTC is evaluated at -10 °C, condensation pressure is dynamic dependent on ambient air temperature (10K temperature difference in air cooler). CTES storage is ideal, i.e. no heat losses.

4 Results and discussion

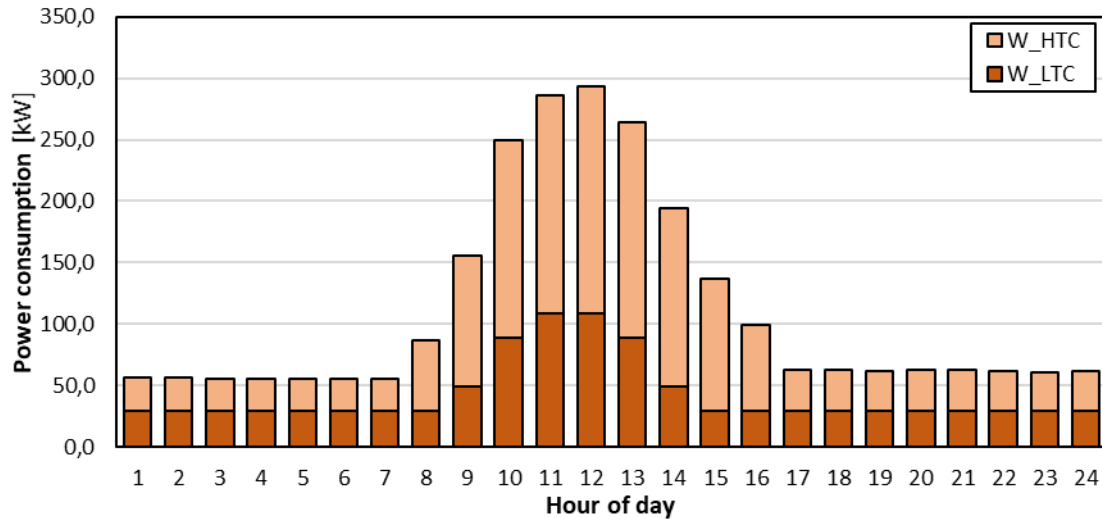

Figure 6: Hourly power consumption for the case without CTES

For the case with no integration of CTES, the power consumption can be viewed in the figure above. As expected, the profile resembles the production pattern of the plant. Peak power consumption, a value often used for determination of electricity demand charges, is in this case just shy of 300 kW. Overall electrical energy consumption for a 24-hr period accumulates to 2655 kWh.

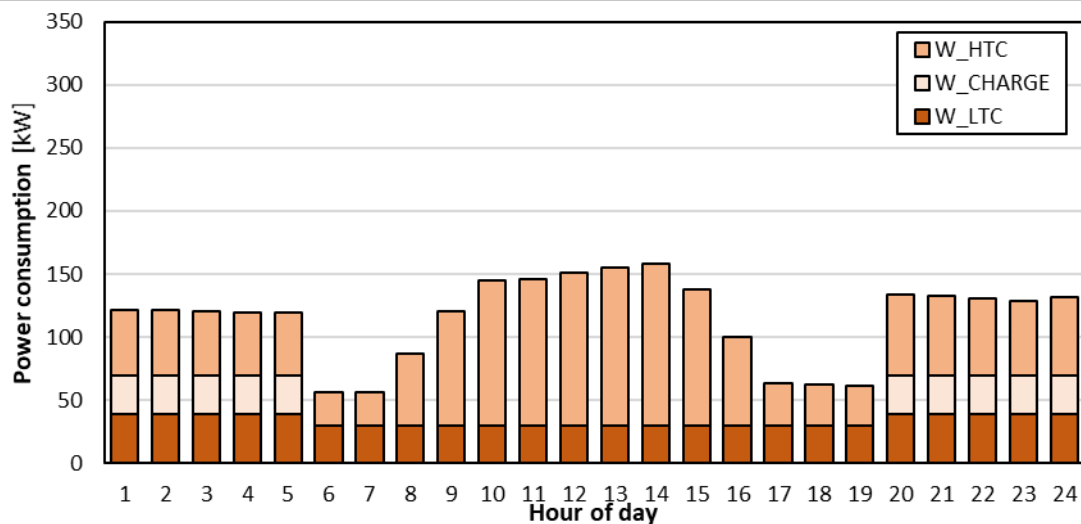

Figure 7: Hourly power consumption with integrated CTES solution

First thing to notice when integrating CTES is that the maximum power consumption is almost reduced by 50%, from 300 kW to 157 kW. Given the previous argument about how electrical demand charges are calculated, this could induce significant savings on said charge. The cost, in energetic terms, of achieving this is an increase in overall energy consumption; 2757 kWh for the 24-hr period. Even though the storage is considered ideal, this is due to the added energetic cost of charging the storage at reduced pressure levels. To charge the storage, liquid CO₂ must be lower than the phase change temperature of the storage medium to induce heat transfer, and for this study an evaporation pressure equal to -60 °C was used.

Charging the storage influences the power consumption of all compressors; naturally the charger compressor is consuming energy, but the added mass flow in the LTC circuit also affects the LTC compressor which must

handle a larger flow rate as well. In turn, also the HTC compressor work is increased due to the extra condensation heat in the LTC circuit. However, by charging during night-time two effects can be noticed; 1) due to lower ambient air temperatures, the HTC compressor works at reduced pressure ratio and thus more efficiently and 2) typically night-time electrical rates are low-cost compared to rates during daytime.

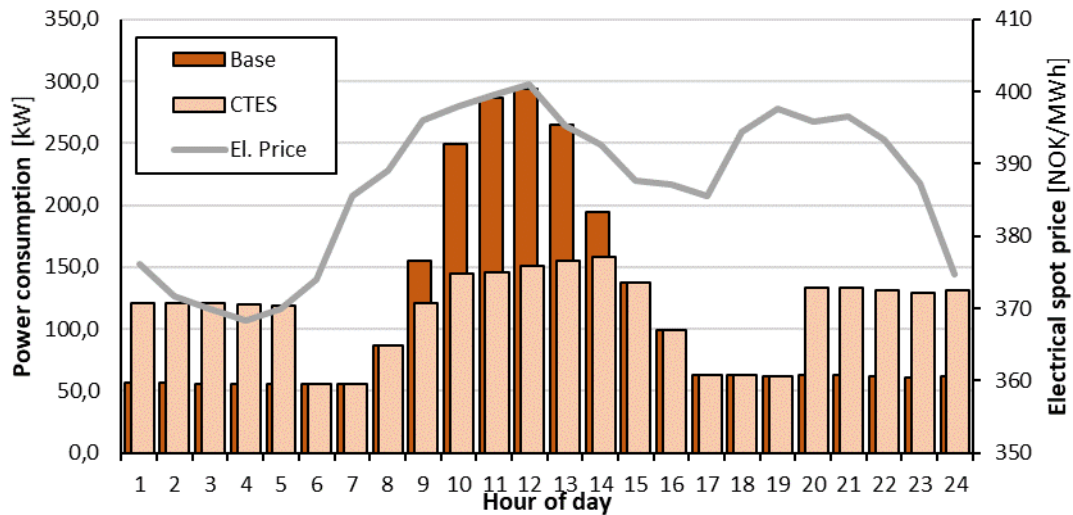

Figure 8: Comparison of both cases, with characteristic electrical price curve throughout a 24-hr period

The latter effect can be observed by looking at Figure 8, which compares total electrical consumption for both cases and also includes a characteristic electrical price curve for a 24-hr period. While an economic analysis is not conducted, it can be assumed that the reduction of demand charges likely outweighs the increased rate charge.

Table 1: Summarized results

Case	Peak power consumption [kW]	Energy consumption 24-hrs [kWh]
Base case	293,8	2655
CTES integration	157,8	2757

Only considering the latent heat of CO₂ as PCM, required mass to store 800 kWh is approximately 14 000 kg, or around 10 m³. In volumetric terms however this only accounts for the required amount of PCM, and dependent on design of CTES storage this value would increase to make room for heat transfer tubes etc. Playing a vital role for this manner is the required charge and discharge rate one would like to achieve, which again is dependent on heat transfer surface area. Large areas are needed for high rates, which in turn increases overall volume of CTES vessel.

5 Conclusions and further work

This study has explored the potential effects of integrating a CTES storage unit in a refrigeration system for an industrial salmon processing plant. Calculations have been carried out in a quasi-static manner, only considering discrete changes on an hourly basis for a 24-hr period and neglecting dynamics in the system. Furthermore, the CTES storage is ideal and provides required charge/discharge rates without concern to possible design constraints. However, the study is a first investigation into the possibilities introduced with CTES integration and known assumptions and simplifications are deemed satisfactory in that regards.

The results of this study show that the integration of CTES can have a large effect on reduction of peak power consumption, and therefore implicitly induce significant savings on the overall electricity bill. Peak power consumption for the refrigeration system with integrated storage was calculated to be 157,8 kW versus 293,8 kW for the case without storage – a 46% reduction. The cost, in energetic terms, for achieving this, is an added energy consumption of 102 kWh for a 24-hr period. It was however assessed that in an economical perspective this increase would likely be insignificant compared to the reduction in peak power consumption. Furthermore, the added energy consumption occurs during low-cost hours at night, and also at hours with reduced ambient air temperature which for this air-cooled refrigeration system provides improved operational working conditions for the compressors.

For industries with low-temperature refrigeration demands strongly linked to production flow, this study has proven a nice fit with the CTES technology. Research is currently being conducted into suitable phase change materials for low temperatures, where one of the challenges to overcome is achieving sufficient heat transfer abilities. Further investigations for exploring CTES potential should simultaneously be carried out on a case-by-case study, given the range of different objectives this technology could serve in an energy system. Such case studies should be carried out with improved dynamic, energy analyses/simulations with different conceptual integration designs.

6 References

- [1] F. Ziegler, U. Winther, E. S. Hognes, A. Emanuelsson, V. Sund, and H. Ellingsen, “The Carbon Footprint of Norwegian Seafood Products,” *SINTEF Fisheries and Aquaculture*, vol. SFH80 A096, 2009.
- [2] Statistics Norway, “08205: Energibruk, energikostnader og energipriser i industrien, etter energiprodukt, næring (SN2007), statistikkvariabel og år. Statistikkbanken.” [Online]. Available: <https://www.ssb.no/>. [Accessed: 02-Dec-2019].
- [3] “Norsk Klimaservicesenter.” [Online]. Available: <https://klimaservicesenter.no/observations/>. [Accessed: 06-Dec-2019].
- [4] A. Hafner, T. S. Nordtvedt, and I. Rumpf, “Energy saving potential in freezing applications by applying cold thermal energy storage with solid carbon dioxide,” *Procedia Food Science*, vol. 1, pp. 448–454, 2011.
- [5] I. H. Bell, J. Wronski, S. Quoilin, and V. Lemort, “Pure and Pseudo-pure Fluid Thermophysical Property Evaluation and the Open-Source Thermophysical Property Library CoolProp,” *Ind. Eng. Chem. Res.*, vol. 53, no. 6, pp. 2498–2508, Feb. 2014.