

Deliverable D4

Metrological guidelines for the validation, calibration and quality control of online gas analysers and sensors performing analysis of hydrogen contaminants regulated in EN 17124:2018 and ISO/FDIS 14687

Project name: MetroHyVe 2

Grant agreement: 19ENG04

Lead partner: NPL

Authors: T. Bacquart, C. Blondeel, Kjos O., P. Dimopoulos, F. Haasenleder, T.A. Aarhaug, R. Gierden, A. Brown, J. Malkinson, K. Arrhenius, Z. Chen, K. Schroter

Due date: 31 July 2023

Submission date: 31 October 2023

Version: 0

This project “Metrology for Hydrogen Vehicles 2” (MetroHyVe 2) has received funding from the EMPIR programme co-financed by the Participating States and from the European Union’s Horizon 2020 research and innovation programme under Grant agreement No [19ENG04].

EMPIR



The EMPIR initiative is co-funded by the European Union's Horizon 2020 research and innovation programme and the EMPIR Participating States

<https://www.sintef.no/projectweb/metrohyve-2/>

Metrological guidelines for the validation, calibration and quality control of online gas analysers and sensors performing analysis of hydrogen contaminants regulated in EN 17124:2018 and ISO/FDIS 14687															
Funding European Metrology Program for Innovation and Research	Grant agreement no: 19ENG04														
Project name Metrology for Hydrogen Vehicles 2	Project short name MetroHyVe 2														
Author(s) <table border="0"> <tr> <td>Claire Blondeel</td> <td>Air Liquide</td> </tr> <tr> <td>Thomas Bacquart, Ziyin Chen</td> <td>National Physical Laboratory</td> </tr> <tr> <td>Ole Kjos, Thor A. Aarhaug</td> <td>SINTEF</td> </tr> <tr> <td>Fabian Haasenleder, René Gierden</td> <td>EMCEL</td> </tr> <tr> <td>Ashley Brown, Jamie Malkinson</td> <td>ITM Power</td> </tr> <tr> <td>Karine Arrhenius</td> <td>RISE</td> </tr> <tr> <td>Panayotis Dimopoulos, Karin Schroter</td> <td>EMPA</td> </tr> </table>	Claire Blondeel	Air Liquide	Thomas Bacquart, Ziyin Chen	National Physical Laboratory	Ole Kjos, Thor A. Aarhaug	SINTEF	Fabian Haasenleder, René Gierden	EMCEL	Ashley Brown, Jamie Malkinson	ITM Power	Karine Arrhenius	RISE	Panayotis Dimopoulos, Karin Schroter	EMPA	Pages 49 pages
Claire Blondeel	Air Liquide														
Thomas Bacquart, Ziyin Chen	National Physical Laboratory														
Ole Kjos, Thor A. Aarhaug	SINTEF														
Fabian Haasenleder, René Gierden	EMCEL														
Ashley Brown, Jamie Malkinson	ITM Power														
Karine Arrhenius	RISE														
Panayotis Dimopoulos, Karin Schroter	EMPA														
<p>Summary</p> <p>This good practice guide was written as part of the activities in work package 2.5 from the EMPIR Metrology for Hydrogen Vehicles 2 (MetroHyVe2) project. The three-year European project commenced on 1st August 2020 and focused on providing solutions to four measurement challenges faced by the hydrogen industry (flow metering, quality assurance, quality control, sampling and fuel cell stack testing). For more details about this project please visit website address.</p>															
Confidentiality	Public														

This project “Metrology for Hydrogen Vehicles 2” (MetroHyVe 2) has received funding from the EMPIR programme co-financed by the Participating States and from the European Union’s Horizon 2020 research and innovation programme under Grant agreement No [19ENG04].



The EMPIR initiative is co-funded by the European Union's Horizon 2020 research and innovation programme and the EMPIR Participating States

Contents

Introduction	4
Implementation of online analysis.....	4
Location of online analysis.....	4
Instrumentation and online analyser available	5
Case study 1: Sensor implementation at HRS in ATEX zone for long term monitoring.....	7
Hydrogen refuelling station specification.....	7
Analytical section implementation	7
Results of the online analysis campaign	9
Case study 2: Sensor implementation at HRS at nozzle (modified feed) for long term monitoring	10
Hydrogen refuelling station specification.....	10
Analytical section implementation	13
Results of the online analysis campaign	14
Evolution of nitrogen over time.....	16
Evolution of water amount fraction over time (ambient temperature)	16
Case study 3: Sensor implementation at HRS at storage location outside ATEX zone.....	19
Hydrogen refuelling station specification.....	19
Analytical section implementation	20
Results of the online analysis campaign	22
summary of good practices and guidelines for online analysis at hydrogen refuelling stations.....	29
Good practices and guidelines prior to implementation.....	29
Good practices and guidelines during implementation.....	30
Good practices and guidelines for online analysis operations	31
Acknowledgement	31
References	31
Annex A – Example of risk assessment	33
Introduction	38
Risk assessment example:	39

Introduction

The deployment of hydrogen refuelling stations across Europe is growing quickly with over 254 HRSs in operation in 2022. Commonly, the quality of the hydrogen dispensed at a Hydrogen Refueling Station (HRS) is controlled according to different standards such as ISO14687:2019 [1], EN17124:2022 [2], or SAE J2719:2011 [3] which include the following gaseous impurities to be monitored: water; total hydrocarbons; excluding methane; methane; oxygen; helium; nitrogen; argon; carbon dioxide; carbon monoxide; ammonia; formaldehyde; formic acid; total sulfur compounds; and halogenated compounds.

Currently, the quality control process is performed by offline analysis of hydrogen fuel. It consists of collecting a sample at the nozzle of the HRS, the sample is then transported to a laboratory where analyses are performed. The complete process can take from a few days to several weeks, however, if this process has the advantage of allowing to check the full compliance with the international standards requirements (ISO14687:2019). However, the nozzle analysis has drawback and can't capture long term events (e.g., performance issue of electrolyser, change of quality due to compressor, degradation of purification capacity) or act on rapid issue (e.g., compressor failure leading to oil contamination, hydrogen batch delivered issues). These events can only be captured based on regular analysis of specific compounds. Then, to complement low frequency nozzle analysis, it became important and useful to monitor canary species on regular basis to ensure that the different processes in the HRS are working efficiently and to anticipate maintenance or issues.

The development of sensors and online analyser has been growing significantly with different objectives as for example, wide implementation of sensors at HRS requiring achieving low cost and acceptable performance [4] or monitoring finely oxygen and water for PEM electrolyser onsite generation at HRS requiring sensitivity and stability of the instrument overtime.

The objectives of this good practice guide are to provide guidelines and recommendations based on experiments realised by MetroHyVe 2 partners.

The report will provide some general guidance on the implementation of online analyser and present several case studies.

Implementation of online analysis

The implementation of online analysis depends on the objective of the monitoring (e.g., performance and control of the sources, monitoring of hydrogen delivered to end users) and on the analysers available and their operating conditions (e.g., pressure, ATEX).

Location of online analysis

Online analysis at hydrogen refuelling station may be realised at different points depending on the overall objectives. Online monitoring can be done before the compressor to control the feedstock quality (e.g., trailer delivery or onsite production), after the compressor (including high pressure storage) to monitor the hydrogen gas quality available for the end user (e.g., discrepancies between hydrogen storage quality, compressor issues) or at the dispenser (e.g., monitoring key impurities potentially contaminating the hydrogen from the HRS).

The figure 1 from Arrhenius et al. [4] summarises the challenges associated with the implementation of sensors at HRS. The actual location is based on the HRS owner objective in relation with its hydrogen quality monitoring plan (ISO 19880-8 [5] or EN17124 [2]).

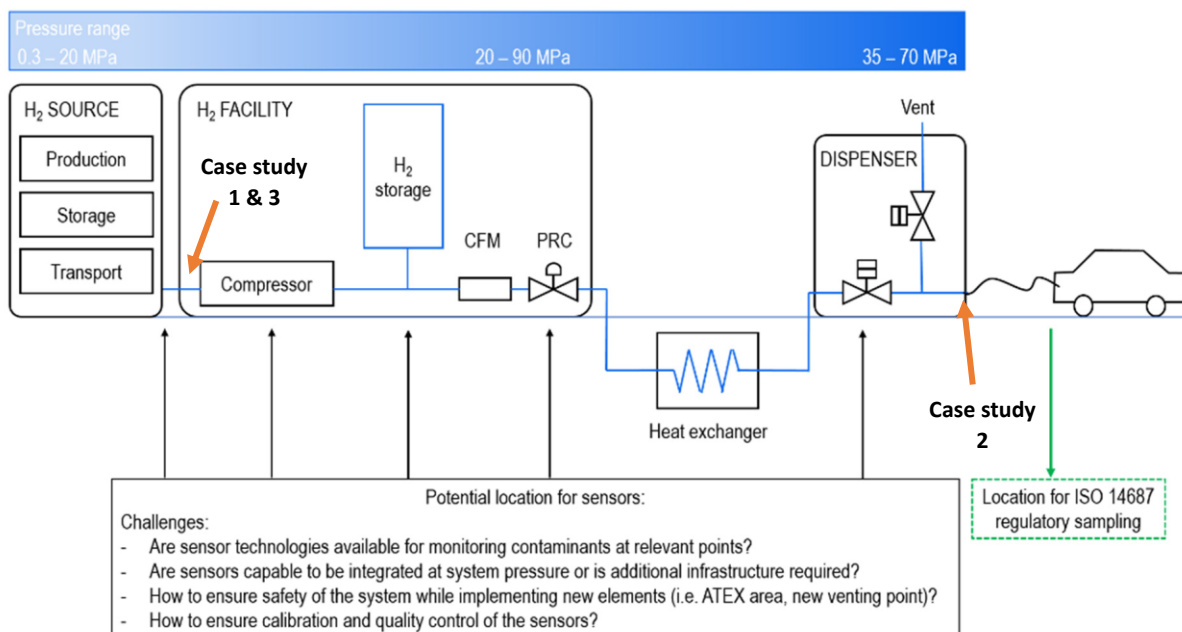

Figure 1. Challenges associated with online analysis at hydrogen refuelling station (reproduced from Arrhenius et al. [4]). The different case studies of METroHyVe 2 are located on the schematic.

Several parameters to consider during the location choice are related to:

- the objective of the measurement, it is important to select an appropriate sampling point (e.g., monitoring gas from trailer needs to be positioned closed to it to avoid other HRS components to impact the results)
- the pressure of the gas and the analyser capability (e.g., analysers are not often capable of analysing high pressure gas).
- analysed gas management (e.g., is the analysis impacting the gas composition? can it be reinjected or need a suitable vent?)
- safety of the system, and where the analyser can be integrated (e.g., can it be within the ATEX zone 2 area or does it need to be outside, therefore the monitored gas needs to be safely transferred to the analyser location)
- ensure space and infrastructure available for calibration of analyser and quality control (e.g., location of calibration gases, additional gas lines)

Instrumentation and online analyser available

Online analysers and sensors were not widely available at the start of the project. MetroHyVe partners highlighted the lack of sensors for hydrogen fuel quality [4]. However, several analysers can be used for online analysis even if their cost is higher than the expectation for low-cost analyser. The MetroHyVe 2 partners reviewed all the analysers available in 2021 and selected instruments that would be suitable for measurement at three hydrogen refuelling stations. The analysers selected focused on most probable contaminants (CH₄, CO, O₂, N₂, H₂O).

The selection of analyser was based on the three different sites and the probability of contaminant presence at the different sites. The MetroHyVe 2 partners realised three online analysis campaign presenting three different scenarios:

- **case study 1:** implementation of analyser in the HRS between the delivered trailer and the HRS delivery parts to monitor the feedstock quality (e.g., hydrogen delivered to HRS compliant with specification). The analyser was implemented in the ATEX zone 2.

Metrological guidelines for the validation, calibration and quality control of online gas analysers and sensors performing analysis of hydrogen contaminants regulated in EN 17124:2018 and ISO 14687

- **case study 2:** implementation of analysers after the nozzle to monitor contaminants from the whole HRS (e.g., production, storage, compressor). The analysers were implemented outside the ATEX zone 2.
- **case study 3:** implementation of analysers at HRS storage point to monitor performance of the onsite production system and local storage (e.g., electrolyser performance). The analysers were implemented in the ATEX zone 2.

The Table below presents the most probable compounds for the three different scenarios.

Table 1. Probability of contaminant presence for the three HRS case studies based on Bacquart et al. [6]

Case study	HRS specificity	Probability of contaminant presence based on Bacquart et al. [6]	
		Frequent and possible	Rare and very rare
1	Feedstock from steam methane reforming delivered by trailer	CO, N ₂	CH ₄ and Ar
2	Onsite PEM electrolyser with high pressure storage	None identified	N ₂ , O ₂ , H ₂ O and CO ₂
3	Onsite PEM electrolyser with low pressure storage	None identified	N ₂ , O ₂ , H ₂ O and CO ₂

A review of the analytical instruments available to determine the selected compounds for each case study. For the case study 2 and 3, all the most probable compounds were measurable (H₂O, CO₂, O₂, N₂) except for oxygen in case study 2. Additional techniques were implemented in case study 2 to study unexpected contaminants. GC-IMS, FTIR instruments with wider scope were implemented to capture any unexpected or novel contaminants that may be present during the online analysis campaign. For case study 1, the objective to operate in ATEX zone 2 was the limiting factor that reduce the number of analyzers available, however 50% of the most probable contaminant were available with the instrument selected.

Table 2. Summary of the online analysis campaign with HRS specificity, parameters monitored, analytical techniques implemented and specification of the sampling point.

HRS specificity	Parameters measured	Instruments	Sampling point
feedstock from steam methane reforming delivered by trailer	CH ₄ , N ₂	Micro-GC/TCD	After the buffer middle pressure, ATEX zone 2 environment, Pressure reduced for analyser
Onsite PEM electrolyser with high pressure storage	H ₂ O Hydrocarbons/ Halogenated N ₂ CH ₄ CO ₂	CRDS (Tiger Optics) GC-IMS (EMCEL) Micro-GC/TCD (Agilent) FTIR	After the nozzle, into a high-pressure vessel and then pressure reduction to 1-10 bar, analyser implemented outside the ATEX zone 2
Onsite PEM electrolyser with low pressure storage	H ₂ O CO ₂ O ₂ N ₂ H ₂ S	OFCEAS (AP2E, Durag) Process GC-PED and QMA (Process sensing) Photoacoustic based sensor (Mirsense) Process GC (ASdevice) CRDS (Tiger Optics) Water sensors	After the buffer tank (20bar), Pressure reduced for analyser (1 5 bar) analyser implemented outside the ATEX zone 2

The implementation of low-cost sensors was considered. The first step was to test and validate the sensors in laboratory condition. It was realised for two sensors by MetroHyVe 2 partner (Air Liquide) and the report is available on the project website [7]. Despite some interesting findings, it has only been progressed with water sensors in one case study.

Following the selection of instrument, the implementation and results of the online analysis campaign is presented, and good practice guidelines are presented based on results and experience gathered by the project partners.

Case study 1: Sensor implementation at HRS in ATEX zone for long term monitoring

In this case study, MetroHyVe 2 partner, Air Liquide, studied and demonstrated how to implement online analysis at a large-scale hydrogen refuelling station in the ATEX zone. The implementation of online analysis in the ATEX zone presents challenges that are presented and discussed in this section as safety requirements, analyser choice, management of gas (inlet and outlet/vent).

Hydrogen refuelling station specification

The experiments were realised at an HRS in Europe with a feedstock from steam methane reforming. The hydrogen gas is delivered by trailer. Therefore, the online contaminant monitoring will focus on Hydrogen refuelling stations (HRS) with SMR feedstock. Based on the probability of occurrence of ISO 14687 contaminants in hydrogen [6], the online monitoring study targeted some of the most relevant contaminants: nitrogen (N₂) and methane (CH₄) in the hydrogen fuel.

For the online monitoring, the sampling point used for the measure of the hydrogen quality is located at the entry of the refuelling station, after the delivery point, on an ATEX zone. It is a critical point for online monitoring as it ensures that the hydrogen gas feed is compliant.

Analytical section implementation

The measurement of hydrogen quality flow at hydrogen refuelling stations comes with challenges in terms of analysers, implementation, and safety. The following section will detail the different challenges and points related to it.

Safety, ATEX zoning and implementation at HRS

Before the implementation in the ATEX zone, several safety aspects have to be taken into account as prerequisite in the choice of the analyser:

- The instrument should be compliant with the ATEX zoning of the implementation zone.
- The wiring should be compliant with the ATEX zoning of the implementation zone.
- The instrument connection type has to be leak tight (to minimize the risk of hydrogen)
- The venting requirements of the instrument should be compliant with the site requirements and ATEX zoning or ported in a safe venting area.

In addition, more general safety aspects have been taken into account for the sampling system:

- The working pressure of the pressure regulators should be appropriate for the inlet and outlet pressure, the pressure regulators should be compliant with local pressure regulation (i.e., trailer pressure type)
- The venting requirements of the safety valves, the safety valves should be ported in order to allow release in safe venting area in case of safety valves activation

Metrological guidelines for the validation, calibration and quality control of online gas analysers and sensors performing analysis of hydrogen contaminants regulated in EN 17124:2018 and ISO 14687

Analyser selection for an implementation at HRS in ATEX zone 2

Currently, online gas analysers are not often designed and certified to operate in ATEX area (zone 2). Most of the online analysers are therefore fitted into an ATEX enclosure if there is a requirement from a specific activity or customer to use the analyser in ATEX environment. Therefore, the number of commercially available ATEX online analysers is currently low. For this study, only an ATEX micro gas chromatography system (micro-GC) has been installed at the hydrogen refuelling station in November 2022.

The micro-GC is equipped with a micro thermal conductivity detector. It allows the measurement of nitrogen and methane at $\mu\text{mol/mol}$ levels meeting the specifications of ISO 14687, 300 $\mu\text{mol/mol}$ and 100 $\mu\text{mol/mol}$, respectively. The advantage of gas chromatography is to allow the separation of nitrogen and methane from any known compounds and therefore allows clear identification of the nitrogen and methane through retention time. The column used is a molsieve packed column (15 meters).

The analyser is composed of several inlets: sample gas, calibration gas, actuation gas, carrier gas and outlets: gas sample, actuation, carrier gas.

The sampling system includes a double pressure regulator to obtain the working pressure without pressure variations, safety valves and a fast loop. The working pressure of the analyzer is 1 bar gauge.

Analytical methods and calibration

The analyser was previously calibrated by the supplier check before the monitoring of nitrogen and methane by using a calibration standard gas with a composition near the specifications of ISO 14687, nitrogen and methane in hydrogen matrix, 320 $\mu\text{mol/mol}$ and 101 $\mu\text{mol/mol}$ and a relative uncertainty of 5%, respectively.

The analytical column used to monitor nitrogen and methane concentrations at the same time is a molsieve column. This type of analytical column is known to have reduced separation efficiency in presence of moisture and carbon dioxide. Before using it, a blackout of the column was installed to remove any traces of contaminants.

The analytical method realises the analysis of nitrogen and methane in less than 90 seconds. During the one-month measurement campaign, several parameters are checked:

- the retention time of each compound to avoid coelution,
- the time of analysis,
- the noise of the baseline,
- the concentration of the compounds obtained from the calibration standard gas (four times).

One way to assess the stability and to prevent a possible drift is to build a control chart. Usually, two types of limits define the control chart, lower/upper warning limit (LWL/UWL) associated with an adjustment of the analyzer and lower/upper control, or action limit (LLC/LLC) associated with an abnormal value and requiring intervention. The averages obtained from the calibration standard gas are reported on this control chart. During the time of the experimentation, no drift was observed.

Figure 2 shows the control chart for the nitrogen.

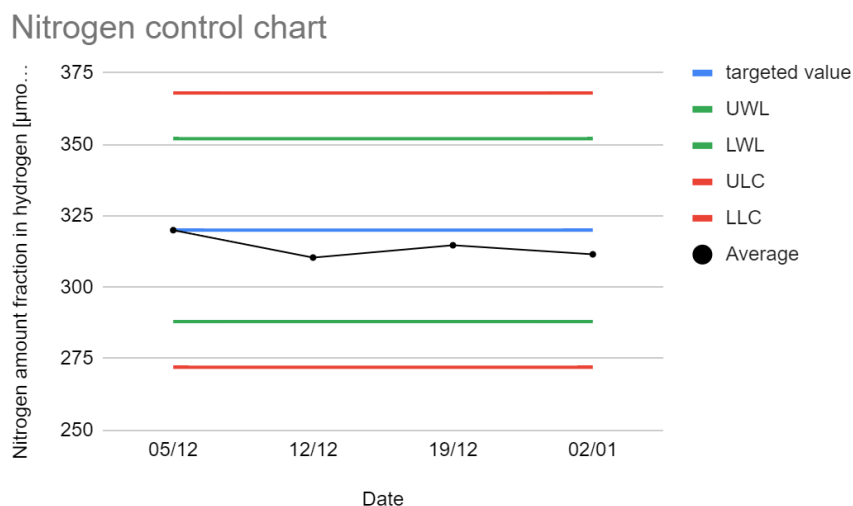

Figure 2. Nitrogen amount fraction control charts during the analytical campaign. The blue line represents the targeted value, the red lines represent the upper and lower control or action limits (ULC and LLC respectively), the green lines represent the lower and upper warning limit (LWL and UWL respectively).

Results of the online analysis campaign

Nitrogen and methane are measured continuously and all the events at the refuelling station were recorded (i.e., refuelling of buses or cars and changing of hydrogen trailers). The evolution of nitrogen and methane were investigated in relation to the different events at the refuelling station in order to identify variation due to the HRS operations.

Figure 3 shows the response of nitrogen and Figure 4 the response of methane at the entry of the refuelling station. The blue box corresponds to a refuelling, the rose to a changing of trailer and the grey to the analysis of the standard gas cylinder.

The nitrogen and methane response from the HRS monitoring point over the one-month period were always under the specifications (i.e., 300 µmol/mol and 100 µmol/mol) respectively. The quality of the hydrogen trailers meets the ISO 14687 requirements for nitrogen and methane amount fraction.

The nitrogen and methane amount fractions were not impacted by the different events at the refuelling station. Before and after a change of hydrogen trailers, there is no evolution of the nitrogen amount fraction. These results demonstrated that the purge procedures at this HRS were effective.

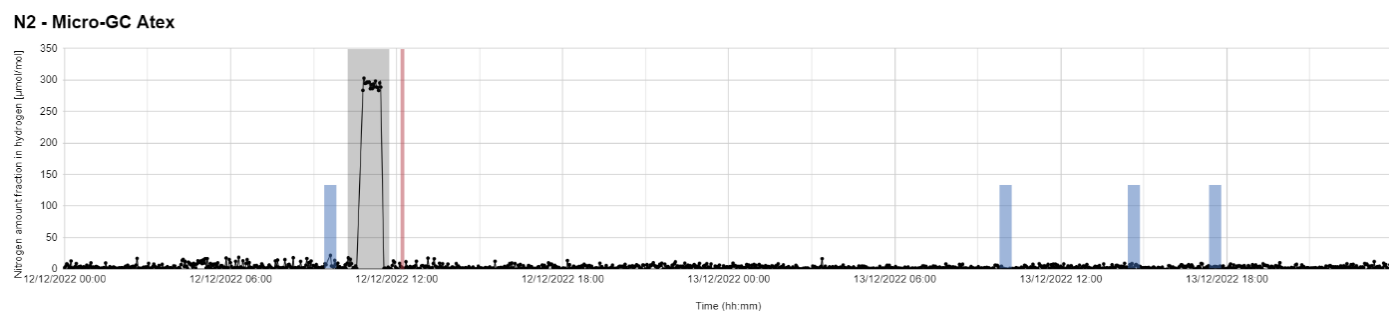

Figure 3. Nitrogen amount fraction in function of time at the entry of the refuelling station

CH4 - Micro-GC ATEX

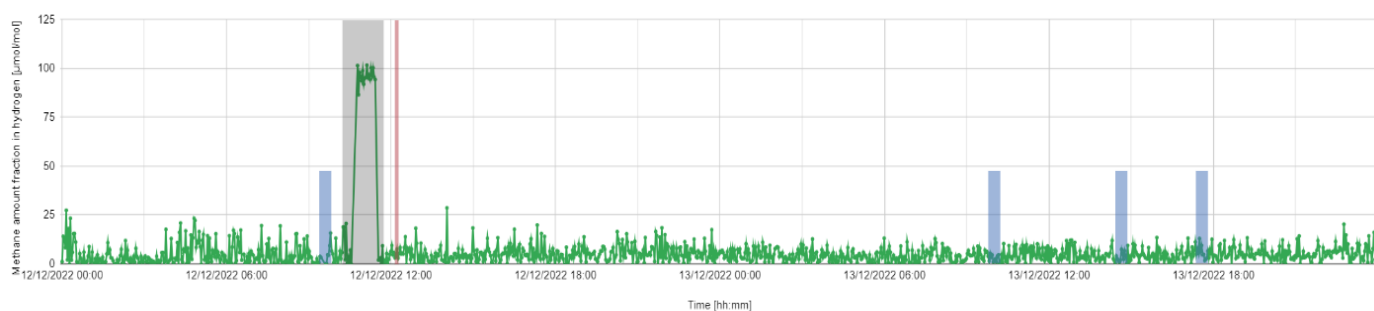

Figure 4. Methane amount fraction in function of time at the entry of the refuelling station

The results of the study demonstrated that the French ATEX micro-GC can monitor methane and nitrogen amount fraction at the ISO 14687 threshold levels in an ATEX environment without significant drift or re-calibration requirement. The original method requires improvements at low $\mu\text{mol/mol}$ of nitrogen, large fluctuation was observed on reported values (e.g., up to $60 \mu\text{mol/mol}$) while the value after manual investigation (integration) was significantly lower. Such issues may launch corrective actions by operators (i.e., additional purging) due to biased information on nitrogen. The data was extracted without any intervention from the supplier.

This ATEX gas analyzer is the first of its kind, and some laboratory tests have been done to improve its robustness and the software. The gas system inside the ATEX box was not well optimised and the software was not suitable for continuous analysis.

Perspectives

- When evaluating the ATEX analysers available on the market, some suppliers may offer ATEX gas analysers but no ATEX wiring, which is not suitable for the uses in an ATEX zone.

Case study 2: Sensor implementation at HRS at nozzle (modified feed) for long term monitoring

In this case study, MetroHyVe 2 partners (EMPA, EMCEL, SINTEF and NPL) studied and demonstrated how to implement online analysis at a hydrogen refuelling station at the nozzle using an additional storage and using four different analysers. The implementation of online analysis is challenging when implementing a large variety of analysers and over long-term operations (24/7). The results of the implementation are presented and discussed in this section as safety requirement, analyser choice, management of gas (inlet and outlet/vent) and analytical results and performance.

Hydrogen refuelling station specification

The Empa hydrogen refuelling station is equipped with onsite hydrogen production by a 180 kW PEM electrolyser. The produced hydrogen is fed to two different compressors, one reaching 400 bar, and the other 900 bar. The compressed hydrogen is stored in a series of composite bottles (different ones for each pressure level).

Following three attempts to fix a service date with the manufacturer (which have been cancelled by the manufacturer just in the week prior to the scheduled date), it was decided in autumn 2022 to close down the 900 bar line, also in anticipation of possible energy shortages in the following winter. Therefore, only the 350 bar line was available for the measurements in the frame of this project.

Metrological guidelines for the validation, calibration and quality control of online gas analysers and sensors performing analysis of hydrogen contaminants regulated in EN 17124:2018 and ISO 14687

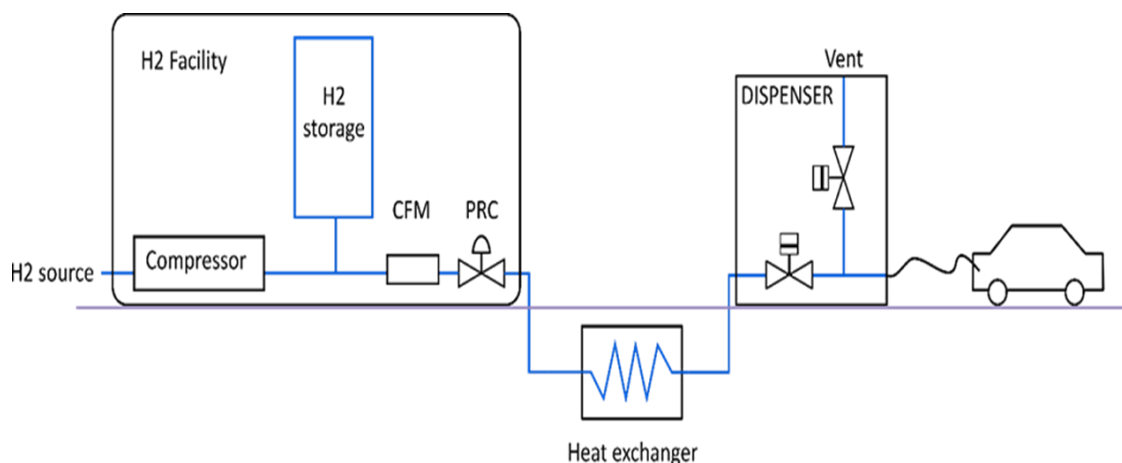

Figure 5. schematic of a typical H2 refuelling station, also representative for the Empa installation

A schematic of a typical setup of a hydrogen refuelling station is shown in figure 5. As already mentioned, the Empa refuelling station comprises of two different compressors and two different storage units for the two pressure levels. As required for the refuelling of gaseous fuels, each of the two storage units consists of a series of composite bottles. Following the storage units, the metering device (Coriolis Flow Meter, CFM) is installed for determining the mass dispensed to the refuelled vehicle. Downstream the CFM a pressure ramp controller (PRC) is installed. Only in the high-pressure line (900 bar), hydrogen passes through a cooling unit (Heat exchanger) upstream the dispenser. The dispenser integrates the interface to the vehicle as well as the necessary ventilation and purging lines.

A significant detail for the present project, turned out to be a safety feature installed in the system: To avoid excessive hydrogen leakage to the environment, the refuelling operating system was equipped with a cut-off, should hydrogen flow through the dispenser be detected for longer than a specified time. The maximal time selectable by the user was 20 minutes. There was no way identified, for by-passing this cut-off. On the other hand, the aim of the present project was the measurement of all possible substances and impurities in the hydrogen of a refuelling station during long time periods. To overcome this conflict and provide the possibility of long time (in the order of several days) analysis, a special setup was designed and implemented.

The Empa setup for the measurements

A schematic of the setup for the present measurements is shown in the figure 6. A (steel) gas cylinder with a volume of 50 L was refilled periodically at the dispenser of the refuelling station. This gas cylinder was portable and will be addressed from now on as "portable bottle". This portable bottle was then connected and fed to the analysers. The portable bottle had to be refilled after a couple of days (depending on the hydrogen requirements of the analysers). The red line in the above figure shows the pressure time history in the bottle during the outflow to the analysers. Following each refill and at the start of each measurement period, the bottle pressure was at 250 bar. The pressure at the entrance of the analysers was kept constant at 2 bar. However, the pressure in the bottle (feeding the analysers) was decreasing over each measurement period. This should be kept in mind in combination with possible condensation effects in the bottle during a measurement period.

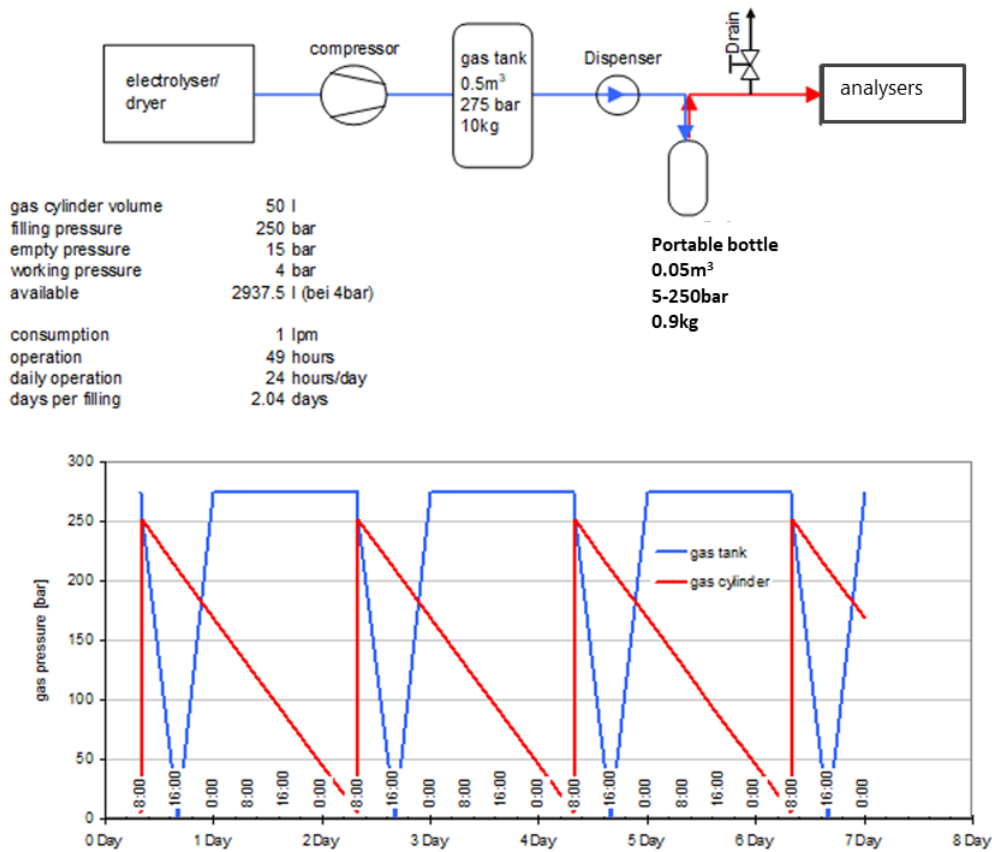

Figure 6. Schematic of the Empa setup for the measurements of the present project

Figure 7 shows the installation of the portable bottle with the necessary valves and pressure reduction units upstream the analysis instruments, as used. In addition, the setup allowed the connection of two analysers in parallel, allowing direct comparison.

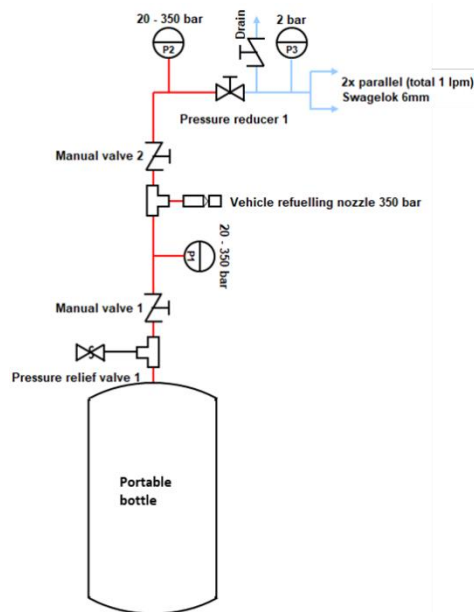

Figure 7. Detailed schematic of the portable bottle and the connection towards the dispenser for refilling and the instruments (blue lines)

Analytical section implementation

The different analysers are described in the section below.

GC-IMS and MicroGC (Outdoor-capable measuring cabinet)

The GC-IMS and the MicroGC were integrated into an outdoor-compatible measuring cabinet. In addition to the two measuring devices, the cabinet consists of a gas control system that sets the pressures and flow rates for the two measuring devices. A safety concept is also integrated into the cabinet, including an H₂ sensor, ventilation, and emergency shut-off. The detectors and GC columns of the two measuring devices were heated to a constant temperature. Additionally, the measuring cabinet was equipped with a heater that switched on when the ambient temperature (inside the cabinet) was too low.

The GC-IMS performs a measurement approx. every 3 minutes (includes the measurement of positive and negative ions). A 15 m GC column is integrated in front of the detector for better selectivity. The adjusted pressure of the hydrogen is approx. 0.2 bar gauge. Dry air is used as carrier and drift gas. The GC-IMS was calibrated for the following substances: H₂S, SO₂, NH₃, ethyl mercaptan, formic acid, HCl.

Two separate GC columns, each with a thermal conductivity detector, are integrated into the MicroGC. The pressure of the analyte gas is about 1.2 bar gauge. Hydrogen 6.0 is used as carrier gas, which is provided by a gas cylinder at approx. 4 bar gauge. The MicroGC was calibrated for the following substances: Helium, argon, oxygen, nitrogen, methane, carbon monoxide, carbon dioxide and ethane.

Fourier Transform Infra-Red (FTIR)

The FTIR setup utilized an ABB Bomem FTIR with a 10.4 m light path cell. The optics and electronics of the FTIR was purged with N₂ to avoid interference of moisture, CO₂ and other gases from the ambient air. The FTIR together with mass flow controllers for H₂ and purge gas was installed in a transport casing from SKC. The box was also equipped with a H₂ alarm system that would cut electricity to the box as well as hydrogen supply if the level of H₂ inside the box exceeded 10 % LEL. H₂ supply was secured by a normally closed magnet valve that ensured stop in the hydrogen supply if power was lost. In addition, the MFC used to control hydrogen flow was normally closed.

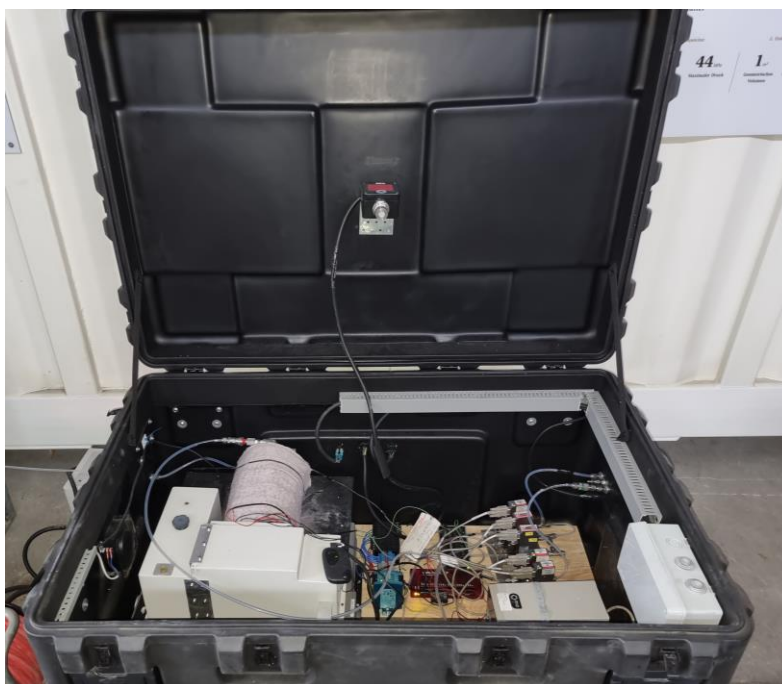

Figure 8: Picture of the FTIR (left) installed together with control electronics and MFCs inside a transport box. Hydrogen detector can be seen in the lid.

The FTIR analysis cell was heated by intrinsically safe heating elements that stabilized at (45 ± 1.5) °C. The heating elements are self-regulating as they have increased resistance as temperature increases. The heating of the cell reduces the tendency of sticky gases such as H₂O to adsorb on the surface of the cell.

Cavity ring down spectrometer (CRDS)

Water was measured using a cavity ring down spectrometer, (SPARK, TigerOptics, US). Gases were sampled directly from the gas cylinder to the analyser, the flow was adjusted to 0.5 L/min for the analysis (pressure close to atmospheric). The instrument was calibrated against a NPL primary reference material at 5 µmol/mol H₂O in hydrogen.

Results of the online analysis campaign

The sampling campaign realised approximately 2 months of constant monitoring with large scope analysers. The study investigated the presence of unexpected compounds during long term operation as part of standard operation or short-term events.

Investigation of unexpected contamination or events

EMCEL has implemented two instruments (microGC-TCD, GC-IMS) allowing to monitor several compounds that are not expected to be present. This online monitoring would allow to evaluate if unexpected event.

The micro-GC-TCD has been calibrated for helium, argon, oxygen, nitrogen, methane, carbon monoxide, carbon dioxide and ethane, but can also detect other impurities (especially hydrocarbons). No unexpected compounds (He, Ar, O₂, CH₄, CO, CO₂ or C₂H₆) were detected above the limit of detection. Only a constant nitrogen value was detected with the microGC-TCD.

SINTEF has implemented an FTIR which is capable of measuring most heteronuclear compounds such as H₂O, CO₂, CH₄. Like the micro-GC-TCD, the FTIR was unable to detect any unexpected contaminants during the two weeks campaign (for example, methane above 5 µmol/mol). However, water amount fraction was detected as expected based on the probability of occurrence in PEMWE process.

The GC-IMS implemented by EMCEL has been calibrated for H₂S, SO₂, NH₃, ethyl mercaptan, formic acid and HCl, but can also detect unknown impurities (especially sulphur compounds, complex hydrocarbons, and halogens). No traces of the calibrated substances were detected. Figure 9 shows a heat map of the spectrum of the GC-IMS. The orange marked area is the RIP (reactant ion peak), which always appears in the spectrum when measuring hydrogen (physical property).

Two interesting results are highlighted around the presence of high-water content and unexpected compounds. The green marked area indicates a high-water content in the hydrogen (expected as part of the probability of occurrence), as this peak only appears at high values. The area marked in red reflects unknown impurities that cannot be clearly defined. Typically, complex oils/fats are in this area of the spectrum.

RISE and NPL realised sampling on solid sorbents for thermo-desorption and GC-MS analysis. The tests were performed on tubes packed with Tenax TA 200 mg, 60/80 Mesh following development of MetroHyVe 2 A3.4.8. The results highlighted the presence of octene and decene at very low nmol/mol levels. These additional results identified the presence of low level of hydrocarbons in the hydrogen. The results were coherent with the GC-IMS observations.

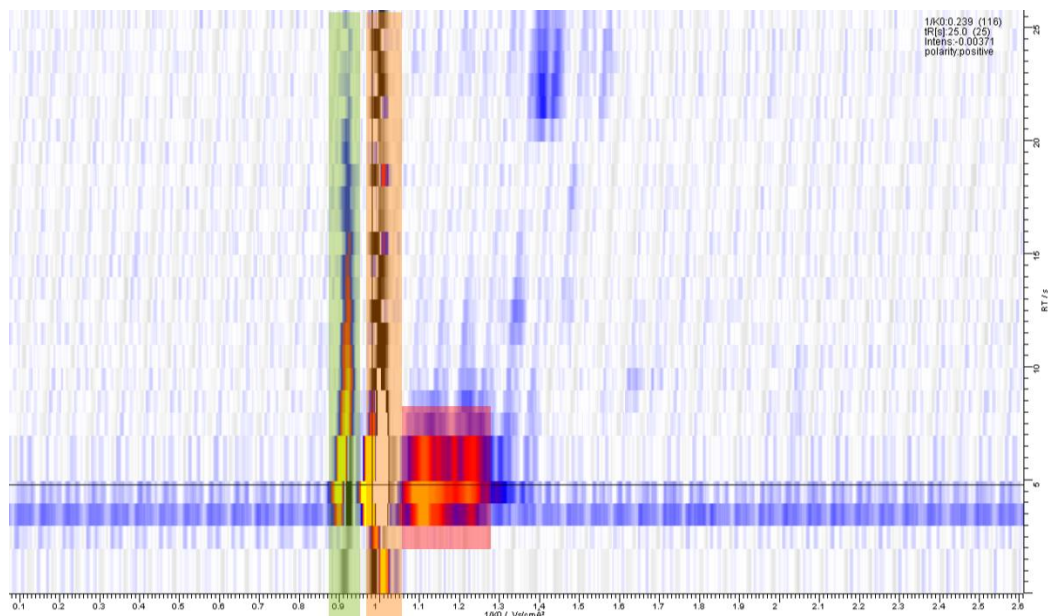

Figure 9: Result of analysis of hydrogen sample by GC-IMS. The figure shows spectrum of GC-IMS with heat map colors to reflect content (white/light blue: nothing, red: high content). The green rectangular shape identifies water, the orange rectangular shape identifies reactant ion peak from the instrument while the small red rectangular shape identifies the unknown compounds.

The results from the different analysers confirmed the absence of most unexpected compounds as part of the probability of occurrence for this HRS (Ar, He, CO, H₂S, SO₂, NH₃, ethyl mercaptan, formic acid and HCl, CH₄, C₂H₆). This study confirms that no unexpected event introduced any of these compounds.

For two compounds that may be present, CO₂ and O₂, the online analysis campaign was not able to capture any presence above the limit of detection of the instruments. CO₂ was only observed by FTIR for very short timeframes (limit of quantification of 0.5 µmol/mol), probably related to refilling of the

sampling container. It highlights the absence of extreme changes during the HRS operations and tend to support lower probability of occurrence for these compounds. For the two other compounds that were expected based on the probability of presence nitrogen and water, observations were made and discussed further below.

Evolution of nitrogen over time

Depending on the sampling container analysed, the value measured by micro-GC-TCD was between 20 and 40 $\mu\text{mol/mol}$. The following **Error! Reference source not found.** shows an example of the analysis of a sampling container, where the nitrogen value was constant at approximately 33 $\mu\text{mol/mol}$. Calibration was performed with several calibration gases containing nitrogen concentrations below, close to and above the limit value according to EN 17124 (300 ppm) to ensure a 5-point-calibration. LOD and LOQ for nitrogen were determined according to ISO 21087. LOD for nitrogen is approx. 2 ppm, LOQ is approx. 7 ppm. Accordingly, the measured concentrations for nitrogen between 20 and 40 ppm are above the LOQ.

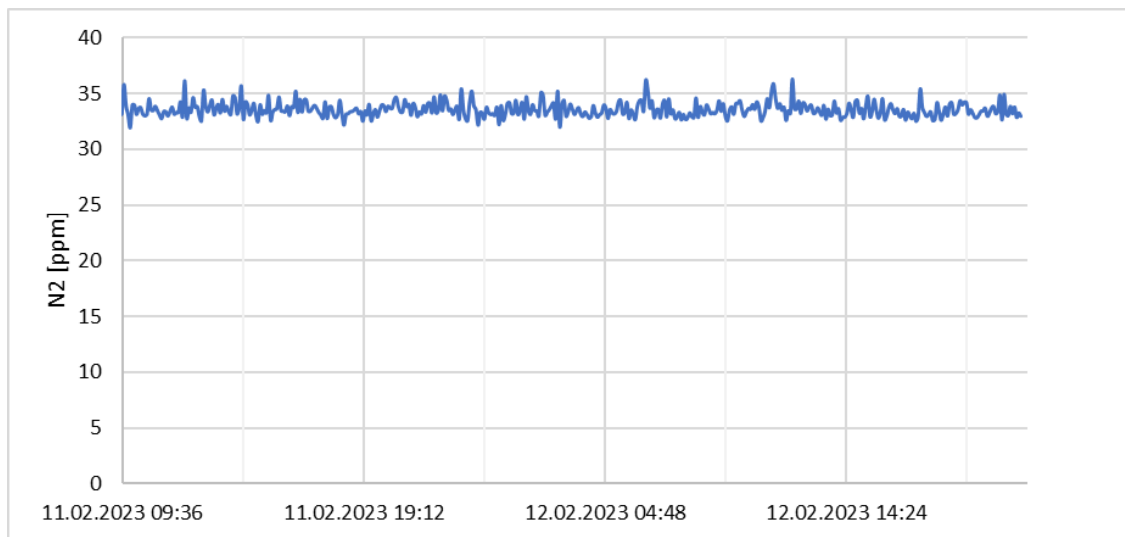

Figure 10: Example of nitrogen amount fraction [$\mu\text{mol/mol}$] measured online by MicroGC-TCD in function of time (over 48 hours)

The results stability over time seems to indicate that the nitrogen amount fraction is stable within the sampling container. Therefore, the variation of nitrogen is more related to operation upstream.

Evolution of water amount fraction over time (ambient temperature)

The FTIR is capable of measuring most heteronuclear molecules including H_2O . The trend for H_2O can be seen in **Error! Reference source not found.**, the high peaks were associated to refilling event of the sampling container. More interestingly, clear daily variations can be seen with increased H_2O amounts around 16:00 and lowest in the morning.

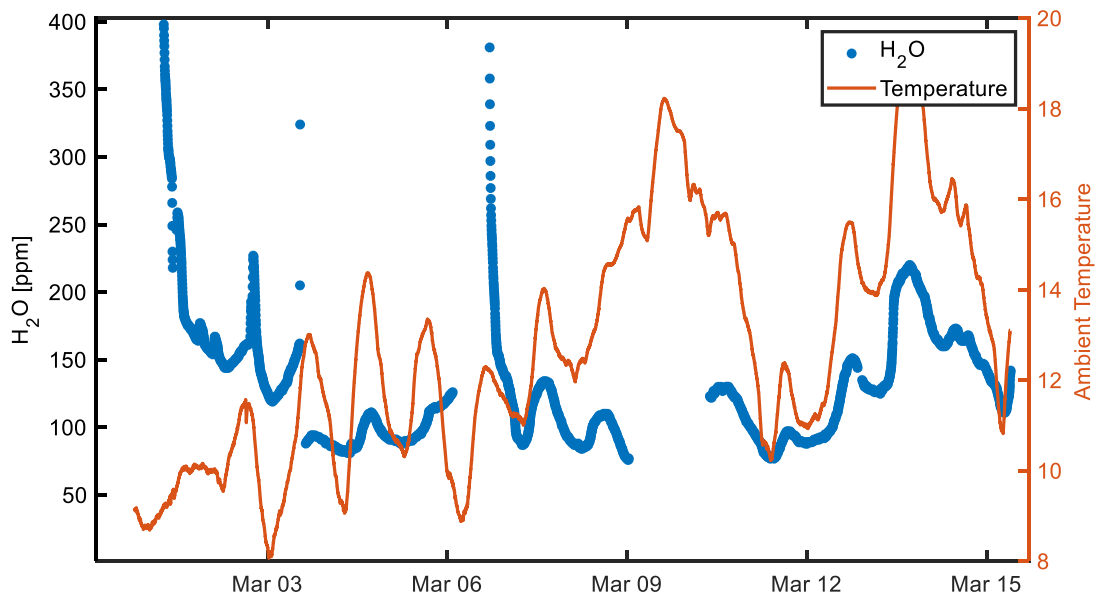

Figure 11: H₂O trends as analysed by FTIR.

Similar observations were made with GC-IMS. The following Figure 12 shows the fluctuating signal at high moisture concentration (see green marked area in Figure 9), as well as the measured hydrogen temperature. The moisture signal at the GC-IMS is not calibrated. It is interesting to see that the water value fluctuates similarly to the temperature of the hydrogen.

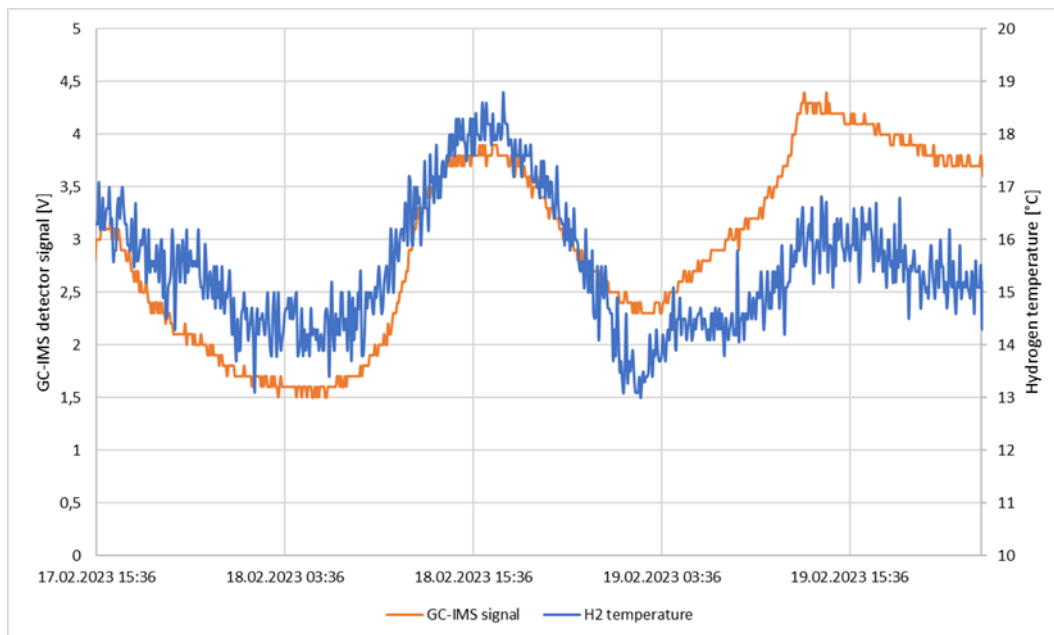

Figure 12: GC-IMS signal for high moisture and H₂ temperature

The results of the CRDS implemented by NPL lead to similar observations than the two other analysers showing high amount fraction of water in the hydrogen delivered from the HRS.

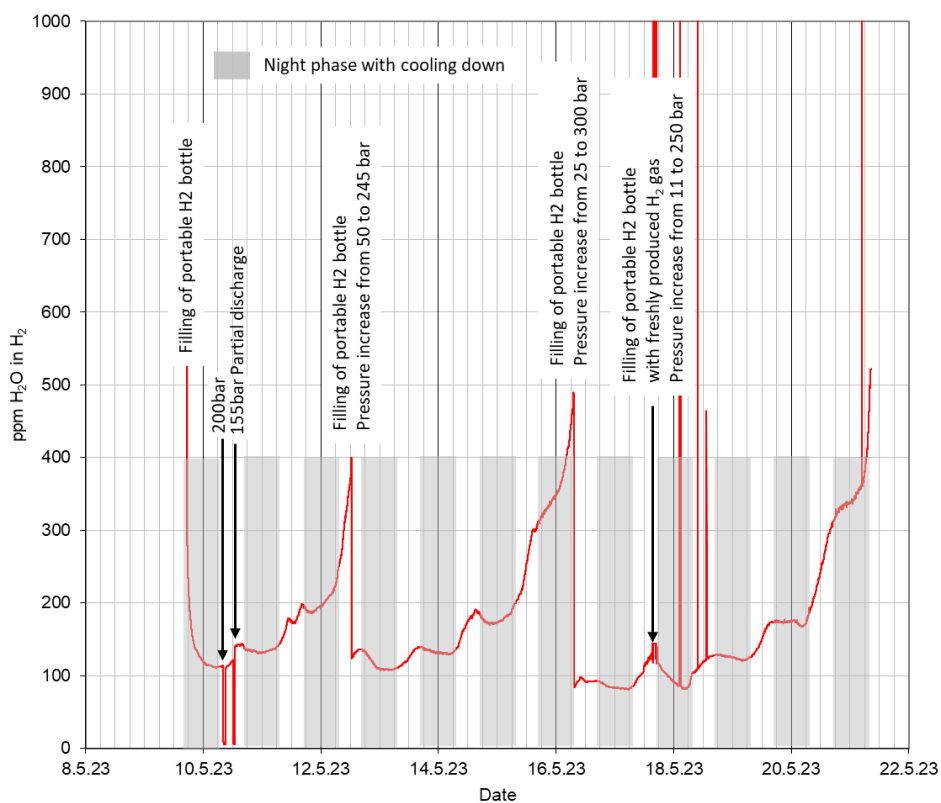

Figure 13. Water amount fraction evolution in function of time. The analysis was realised by CRDS.

The influence of different parameters (temperature, refilling event) on the results was studied, however it is not possible to determine which parameters had the biggest impact on the water amount fraction. The night phase on Figure 13 tends to show a decrease a slower increase of water amount fraction during this phase. It could be related to ambient temperature. Another trend may be related with the pressure in the cylinders (see Figure 13), as the pressure decreases, the water amount fraction increases. It could be related to adsorption and desorption mechanisms on the storage cylinders.

Consecutive measurement – transition between sampling campaign

The results from SINTEF and NPL realised within 1.5 month showed agreement in the water amount fraction range with low value in the range of 75-100 $\mu\text{mol/mol}$ and upper value in 200-250 $\mu\text{mol/mol}$. No major discrepancies were observed between the two systems implemented which is important. It provides some consistency in the results and more reliability in the water amount fraction observed at this hydrogen refuelling station. If possible, it would have been important to ensure overlap between the two measuring systems to ensure their equivalence.

Impact

The study highlighted the high amount fraction of water observed from this HRS. The parameters influencing the variation were not clearly identified (i.e., cylinder material, temperature, day/night) but it provided some evidence to the operators that the current quality needs attention. The study showed that the current probability of occurrence for this case study (no identified contaminant in frequent and possible frequency and only N_2 , O_2 , H_2O and CO_2 in rare and very rare frequency) may be amended. For example, water may become frequent while nitrogen, oxygen and carbon dioxide may be assumed to be very rare due to their complete absence over months of monitoring.

The use of wide scope analysers as FTIR or GC-IMS allowed to investigate unexpected contaminants. The results highlighted the absence of most unexpected contaminants but identifies presence of heavy unknown hydrocarbons. Further study may be required to identify and determine their relevance for future monitoring and hydrogen quality.

Case study 3: Sensor implementation at HRS at storage location outside ATEX zone

In this case study, MetroHyVe 2 partners (NPL and ITM Power) studied and demonstrated how to implement analysers at an HRS buffer tank point to monitor performance of the onsite production system and local storage (e.g., electrolyser performance). The analysers were not implemented in the ATEX zone 2. The results of the implementation are presented and discussed in this section as safety requirement, analyser choice, management of gas (inlet and outlet/vent) and analytical results and performance.

Hydrogen refuelling station specification

The experiments were realised at an HRS in Europe with an onsite proton exchange membrane water electrolyser (PEMWE). The hydrogen gas generated by the electrolyser is stored in a large buffer tank at 15 – 20 bar. This stored gas is then used in the high-pressure compressor to refuel the vehicle.

Therefore, the online contaminant monitoring will focus on Hydrogen refuelling stations (HRS) with PEMWE. Based on the probability of occurrence of ISO 14687 contaminants from PEM produced hydrogen [1], the online monitoring study targeted the higher likelihood contaminants: nitrogen (N₂), oxygen (O₂), water (H₂O) and carbon dioxide (CO₂) in the hydrogen fuel.

For the online monitoring, the sampling point used to measure the hydrogen quality is located at the low-pressure buffer storage (see Figure 14). As the analysers were not ATEX rated, the online sampling point was ported outside the ATEX zone area. This meant that the distance between the sampling point and the analyser was long (10 – 15 meters of pipeline). The analysers required a new venting point each which created a new ATEX zone at the release point which needed to be added to the overall system risk (e.g., venting at height).

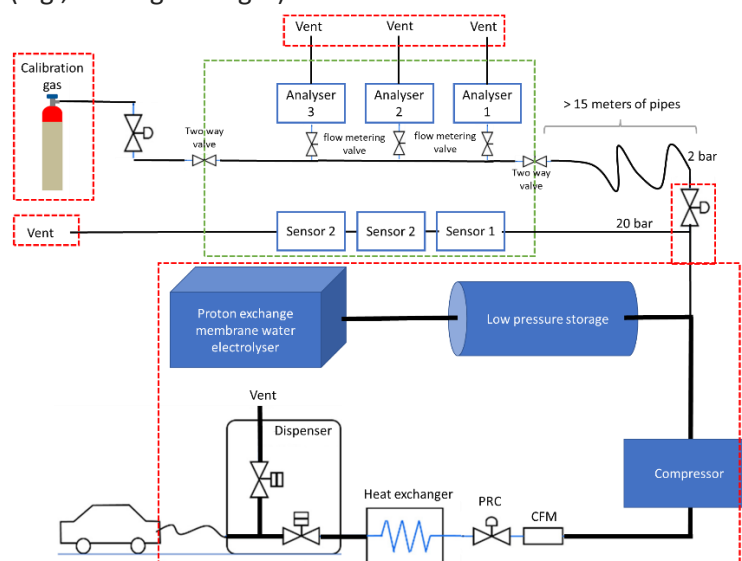

Figure 14. Schematic of the implementation of online analyser and sensors at the hydrogen refuelling stations with onsite production. The red dots represent the ATEX zone identified. The green dots represent the online analyser and sensors zones located outside the ATEX zone, several dozens of meters away from the HRS.

Analytical section implementation

The measurement of hydrogen quality fuel at hydrogen refuelling stations comes with challenges in terms of analysers choice, implementation, and safety. The following section will detail the different challenges and points related to it. The different instruments implemented are presented in the Table 3 with information on range provided by the manufacturers.

Table 3. summary of the analysers implemented, and the different compounds measured. p. means possible based on manufacturer modification of the method or the instruments (i.e., different laser for OFCEAS).

		H ₂ O	CO ₂	O ₂	N ₂	H ₂ S	CO	CH ₄	Instrument parameters		
Technology	Instrument	µmol/mol							Flow (ml/min)	pressure	Analysis time
OFCEAS	Durag	0 - 50	0 - 50	p.		0 - 2	p.	p.	200	0-0.5 barg	10 sec
GC-PED and QMA	MD2 - Process Sensing / LDETEK	0 - 10	0 - 10	p.	0 - 10		0 - 10	0 - 10	200	-	8.5 min
Photoacoustic	Mirsense	0.25 - 500	0.5 - 1000				0.1 - 100		100	1.0 bar	60 sec
GC-PED	Imov - ASDevice		0.1 - 20	0.1 - 20	0.1 - 20		0.1 - 20	0.1 - 20	> 100	4.66 psig	17 min
Cavity ring down spectrometer	Spark - TigerOptic	0 - 2000	p.	p.			p.	p.	450 - 550	atm	20 sec
Metal oxide sensor	n.a.	Frost point -100 °C to dew point 20 °C									
Fibre optic sensor	n.a.	Frost point -100 °C to dew point 20 °C									
Spectrometry sensor	n.a.	Frost point -100 °C to dew point 20 °C									

Safety, ATEX zoning and implementation at HRS

Before the implementation outside the ATEX zone, several safety aspects must be considered as prerequisite in the choice of the analyser:

- The instrument should be located outside the ATEX zoning of the HRS. It may require to be ported a certain distance out (e.g., 10-15 meters).
- The analyser should have access to all utilities (i.e., power, or compressed gas). Several analysers require compressed gas as gas chromatography (i.e., compressed nitrogen for actuator, gas chromatography carrier gas as argon or helium). These additional utilities need to be included on the risk assessment and location has to be compliant with the ATEX zoning of the implementation zone.
- The instrument connection type must be leak tight (to minimize the risk of a hydrogen leak)
- The venting requirements of the instrument should be compliant with the site requirements and ATEX zoning, the vents should be ported in a safe venting area. All venting was realised above 2.5 meters at safe location agreed with the site owner.

In addition, more general safety aspects have been considered for the sampling system:

- The working pressure range of the pressure regulators should be appropriate for the inlet and outlet pressure, the pressure regulators should be compliant with local pressure regulation (i.e., trailer pressure type)
- The venting requirements of the safety valves, the safety valves should be ported in order to allow release in safe venting area in case of safety valves activation.

Instrument description

Cavity ring down spectrometer (CRDS)

Water amount was measured using a cavity ring down spectrometer (SPARK, TigerOptics, US). Gases were sampled directly from the gas cylinder to the analyser, the flow was adjusted to 0.5 L/min for the analysis (pressure close to atmospheric). The instrument was calibrated against a NPL primary reference material containing 5 µmol/mol H₂O in hydrogen.

GC-PED

ASDevices' iMOv GC-PED platform was configured for the measurement of 0.1-20 µmol/mol O₂, N₂, CH₄, CO and CO₂ in hydrogen. For this system, the cycle time is relatively long to allow separation between O₂ and the hydrogen matrix. Without O₂ measurement, the cycle time can be shortened. All the compounds, except CO₂ were measured on a GC channel with molecular sieve 5A (MS5A) columns in a heart cut configuration. CO₂ was measured on a GC channel with a ShinCarbon column in a backflush configuration. The injection volume was 1mL on both channels. Lower measurement ranges, with LODs down to <1 nmol/mol can be achieved for all of these compounds with a larger sample loop. Upon request, the iMOv platform can be configured for the measurement of other impurities in the ISO standard for fuel-grade hydrogen (e.g., sulfur compounds, argon, non-methane hydrocarbons, H₂O). ASDevices PED is based on the "Enhanced Plasma Discharge" (Epd) technology (patented), that uses additional electrodes to stabilize the plasma and improve the Signal to Noise ratio. Furthermore, the digital signal processing unit (DSP) can record and combine up to 4 different signals simultaneously. This allows unique real-time signal treatment methods such as "spectral compensation". Here, spectral compensation was used to reduce the impact of the baseline drift from hydrogen matrix on the oxygen peak. Indeed, on most columns including MS5A, trace oxygen is very difficult to separate from the hydrogen matrix. Spectral compensation is done by combining the measurement from two wavelengths. The first wavelength is very sensitive to oxygen – but its baseline is also affected by the high hydrogen matrix concentration. The second only responds to background variation from the hydrogen matrix. By combining these two signals, it is possible to "extract" the oxygen peak and use it for more accurate quantification. The signal from the other analytes was measured directly from the photodiodes, as they were well separated from the matrix.

GC-PEDs can be operated with argon or helium carrier and discharge gas. Argon was used as the carrier and discharge gas, because the requested LODs were high-enough, and argon is less expensive than helium. Furthermore, the plasma discharge was doped with trace moisture from a permeation tube. This further improves plasma stabilization and generates new light emission bands that can be exploited for the measurement of the analytes. The system was regulating the flow based on input pressure that was maintained around 4.6 psi gauge.

Gas chromatography with plasma emission detector (GC-PED) with quartz crystal micronealance (QMA)

LDetek offers a complete solution for analyzing all the contaminants in hydrogen fuel cells, without requiring third-party analyzers. This is made possible by the use of its patented PlasmaDetek2 detector

Metrological guidelines for the validation, calibration and quality control of online gas analysers and sensors performing analysis of hydrogen contaminants regulated in EN 17124:2018 and ISO 14687

and quartz crystal (H_2O). The first analyzer was typically set up to measure N_2 , CH_4 , CO , CO_2 . This is achieved using a plasma emission detector with selective optical filters. The second detector is quartz crystal (QMA) from Michell instruments which allows the analysis of water amount fraction from low amount fraction to $\mu\text{mol/mol}$. The modular design of the unit allows for configuration based on specific application requirements. The LDetek system was operating with helium carrier gas. The flows were regulated by the system with approximately 100 ml/min for each analyser within the system. The instrument was calibrated against a NPL primary reference material in hydrogen.

OFCEAS

AP2E provided a ProCeas gas analyzer, based on OFCEAS spectroscopy, under a dedicated version to measure H_2S in H_2 . The limit of detection 3sigmas 60 seconds for H_2S was approximately 1 nmol/mol, which is the best achievable for measurement of H_2S with OFCEAS. The device was also able to measure H_2O and CO_2 , but not at optimal limits of detections compare to the best measurement possible with OFCEAS. Limit of detection for H_2O was 0.2 $\mu\text{mol/mol}$, when best achievable for measurement of H_2O with OFCEAS is 10 nmol/mol. Limit of detection for CO_2 was 1 $\mu\text{mol/mol}$, when best achievable for measurement of CO_2 with OFCEAS is 10 nmol/mol. The instrument was operating with a small pump to regulate to flow within the instrument. An overflow of 200 – 300 ml/min was maintained at atmospheric pressure. The instrument was calibrated against a NPL primary reference material in hydrogen.

Photoacoustic sensors

Multisense gas sensor technology is based on laser spectroscopy in the mid-IR using a photoacoustic sensor. It uses the mirSense proprietary Quantum Cascade Laser technology. This combination provides a real time measurement of up to 4 gases at trace concentrations (down to sub-ppm) in an unprecedented compact format (less than 1 liter), within a robust and easy to maintain module. The analyser requires 100 ml/min at atmospheric pressure.

Results of the online analysis campaign

The aim of this exercise was not to look at the performance of the HRS but to review different key aspects of online monitoring. The following key points were observed:

- Comparison of analyser and calibration;
- Distance between online analyser and system;
- Importance of analysis frequency;
- Limit of detection and data interpretation;
- Response time of sensors
- Readiness of sensors.

Comparison of analysers and calibration

An important aspect of online analysis is the calibration of the analyser especially when measuring amount fraction in micromole/mol or ppm. It may often be misinterpreted by operators. Results provided in amount fraction are taken as true or accurate values. It is important to verify the trueness of the instrument reading to avoid bias results.

First, all the instruments installed except the photoacoustic system (MirSense) were working fine when used online on the HRS setup. All the working instruments were calibrated using different NPL calibration gases. Due to health and safety restrictions, a limited number of calibration gas was used on site.

Metrological guidelines for the validation, calibration and quality control of online gas analysers and sensors performing analysis of hydrogen contaminants regulated in EN 17124:2018 and ISO 14687

Most instruments in the campaign could not provide a fully accurate result without a calibration performed at the location of use, however, the values initially reported were within the correct order of magnitude (no response factor above 2 or below 0.5). Below is example of observed limit of detection and response factor from the experiment realised by NPL. We should be bear in mind that not all instruments were setup for this type of analysis in hydrogen and were used as received without adjustment from the manufacturers. For longer installation and calibration, the instrument manufacturers can normally provide tailored adjustment based on customer requirements. However, in this case, due to the short time of the sampling campaign and the lack of connectivity at the HRS for remote access, it is not feasible.

Table 4. Summary of the observed limit of detection and response factor based on the onsite calibration realised by NPL. n.m. means not measured and n.a. means no measurement achieved, system failed to function at the site.

Technology	H ₂ O	CO ₂	O ₂	N ₂	H ₂ S	CO	CH ₄
	µmol/mol	µmol/mol	µmol/mol	µmol/mol	µmol/mol	µmol/mol	µmol/mol
OFCEAS	RF: 0.78 0 - 50	RF: n.a. LOD: 2.1			0 - 2		
GC-PED and QMA	RF: 1.10 LOD: 0.3	RF: 0.82 LOD: 0.02		RF: 1.34 LOD: 0.3		RF: 1.86 LOD: 0.010	RF: 1.88 LOD: 0.010
Photoacoustic	n.a.	n.a.				n.a.	
GC-PED		RF: 0.66 - 0.74 LOD: 0.15	RF: 1.13 - 1.32 LOD: 0.13	RF: 1.52 LOD: 0.3		n.m.	RF: 0.80 LOD: 0.025
CRDS	RF: 0.97 LOD: 0.10						

For example, a discrepancy between the CRDS and the OFCEAS analysers were observed for the water amount fraction (see Figure 14). When the two instruments were used to measure primary reference materials (NPL calibration gas), a difference with the certified value was observed for the OFCEAS response which reported a value approximately 20% higher at 5 µmol/mol whereas the CRDS response was within 3% of the certified value.

Another important challenge is the use of suitable calibration gases. Due to the additional risk (flammability and compressed gas) that the presence of these gases presents at HRS, the number of gases to be used onsite is limited, it is therefore advantageous to select multi-components calibration gas. Multicomponent calibration gases are bespoke realisation and may require precise specification from the instrument working range prior to the realisation of the gas calibrant. During the project, several NPL multi-components gas calibrants were used in MetroHyVe 2 activity 2.2. Therefore, the amount fractions of all the compounds in hydrogen were not directly tailored to all instrument requirements.

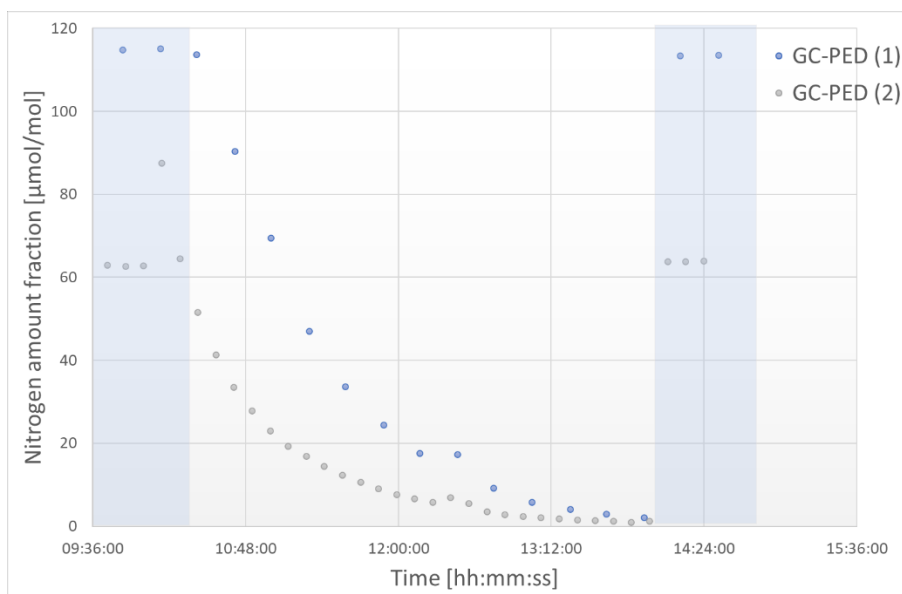

Figure 15. Difference observed due to potential calibration issues. The results are from two GC-PED system with different ranges calibrated using a 70 µmol/mol nitrogen in hydrogen standard. The standard was over the working range of the instrument, therefore the detector was saturated and the response factor was incorrect.

Defining the right calibration gas and using multi compounds calibration gas is better to calibrate the instrument according to its optimum range while limiting the number of gas cylinder and calibration point to realise. A calibration exercise may require 0.5-1 hour to have stable readings and depending on the instrument stabilisation time and frequency of analysis. Therefore, using a gas calibrant per compound would require 2.5-5 hours of calibration time if 4-5 compounds are analysed. Then, a bespoke gas calibrant would save a large amount of time if it is suitable for all compounds. In the Figure 15, it is obvious that the calibration gas was not appropriate for one instrument and therefore provided a biased result (the evolution of nitrogen amount fraction is similar for the two instruments).

Distance between online analyser and system

Due to the analysers located outside the ATEX zone, the flow path to the analyser was quite long (more than 10 meters). Even with a flow rate of few hundred millilitres per minutes, the delay from a sample to reach the online analyser may be significant. An illustration of this delay in getting a representative sample of the process can be seen from Figure 16. It represents the time to obtain low nitrogen amount fraction from one analyser as the system was kept overnight under nitrogen flow to keep the line dried and to avoid any flammability risk on an unattended site at night. The results in Figure 16 highlight the complete absence of oxygen and validate the event to be flushing the nitrogen out of the online analysis line.

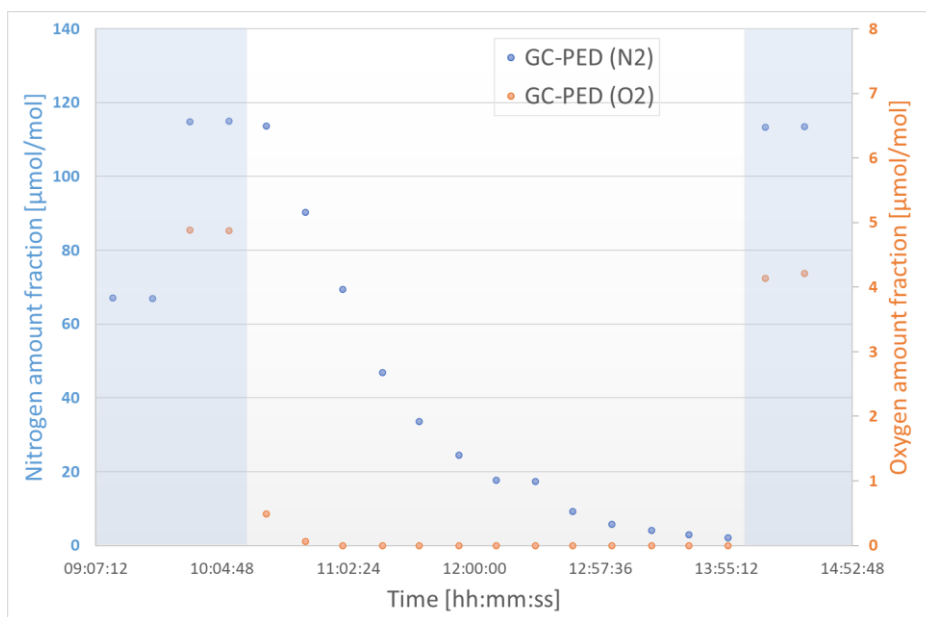

Figure 16. Evolution of nitrogen and oxygen when the online analysis line is switched from nitrogen to hydrogen sample. The measurements were realised on the same instrument and showed the complete absence of oxygen (no air leak) while the nitrogen represents the time to flush the inert gas out of the long line from the sampling point of the HRS to the analyser.

The results showed the importance of realising constant online analysis and the line purging process to ensure the online analyser measurement is representative of the process. At the same time, it highlights the challenges associated with online analysis not being implemented 24/7 and the need to eliminate any non-sample gas from the analytical line prior to obtaining reliable results. It may be critical to determine the time required to reach 100% of the sample gas at the analyser location on the specific site as it may vary based on the distance between the sampling point and the analyser, the pressure of the line and the venting protocol.

Importance of analysis frequency

Online analysers and sensors have various frequency rates to report measurements. It is important to consider the online analyser frequency of analysis in relation to the expected frequency and duration of events at the operation site.

For example, it may be important to get several results per refuelling event. Considering a refuelling event lasting few minutes, several online analysers will not be able to provide one measurement per event. The Figure 17 showed an event around time 12:30 that is well monitored by analyser 1 while analyser 2 only showed two points increased. The frequency of analyser 2 was set to low frequency to improve accuracy however **if this is not considered** it **can** lead to missed events.

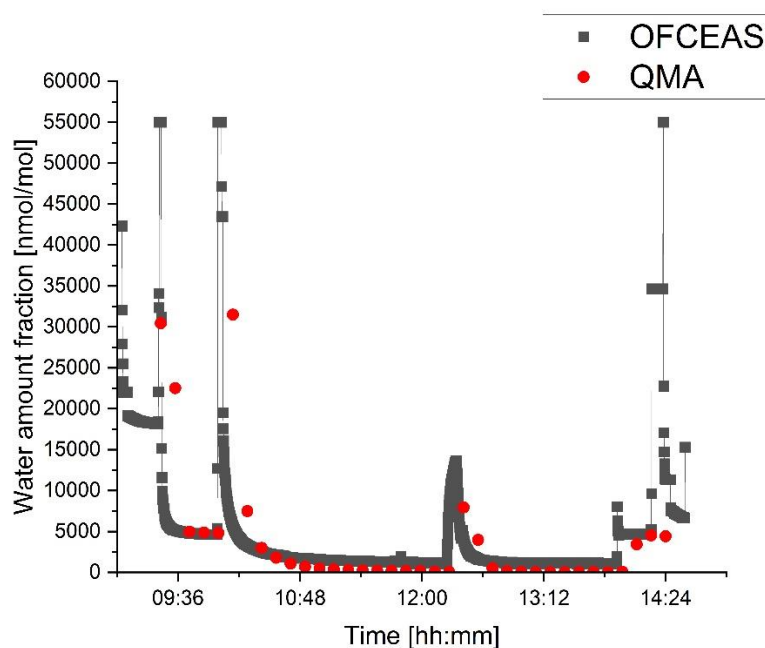

Figure 17. Comparison of two techniques measuring water amount fraction with different frequency of analysis. The OFCEAS (black squares) has frequency around 10 seconds whereas the QMA (red circle) has frequency around 8.5 minutes.

These results demonstrated that it is essential to consider the frequency of analysis while selecting and setting up the analyser. Moreover, instrument manufacturer or analytical expert can modify the frequency of analysis (to a certain extent) based on defined requirements provided by the HRS operation team.

Limit of detection and data interpretation

Every analyser has boundaries in term of analytical ranges. This range may be adjusted following discussion with the manufacturer, however, in operation, it is critical to have a clear idea of the limitation of the instrument in terms of detection limit as the instruments will often report values even if they are under the limit of detection; results could be highly scattered or biased. The OFCEAS analyser was able to provide carbon dioxide amount fraction measurement however the amount fraction around $2 \mu\text{mol/mol}$ was close to the instrument limit of detection for this setup. Therefore, the measurement presented in Figure 16 showed a strong scattering of the results ($\sim 30\%$ relative) despite being true (considering a large uncertainty). The comparison with an analytical method more sensitive but less frequent (GC-PED) highlighted the difference in observation that can be made. The OFCEAS seemed to indicate that the process was completely uncontrolled (strong oscillation of CO_2 from $0 - 3 \mu\text{mol/mol}$). An end-user may have decided to investigate the process to find the sources of variation. Using the GC-PED results, the CO_2 amount fraction seemed to be perfect stable with less than 5 % of relative standard deviation. The challenge with online analyser is their constant readings (no maximum or minimum value for which the software is not providing value) that requires to be carefully considered as the limit of detection may have been determined through extrapolation. In the case of the OFCEAS, the manufacturer informed the MetroHyVe 2 consortium about the high variability of carbon dioxide within the range $0-2 \mu\text{mol/mol}$.

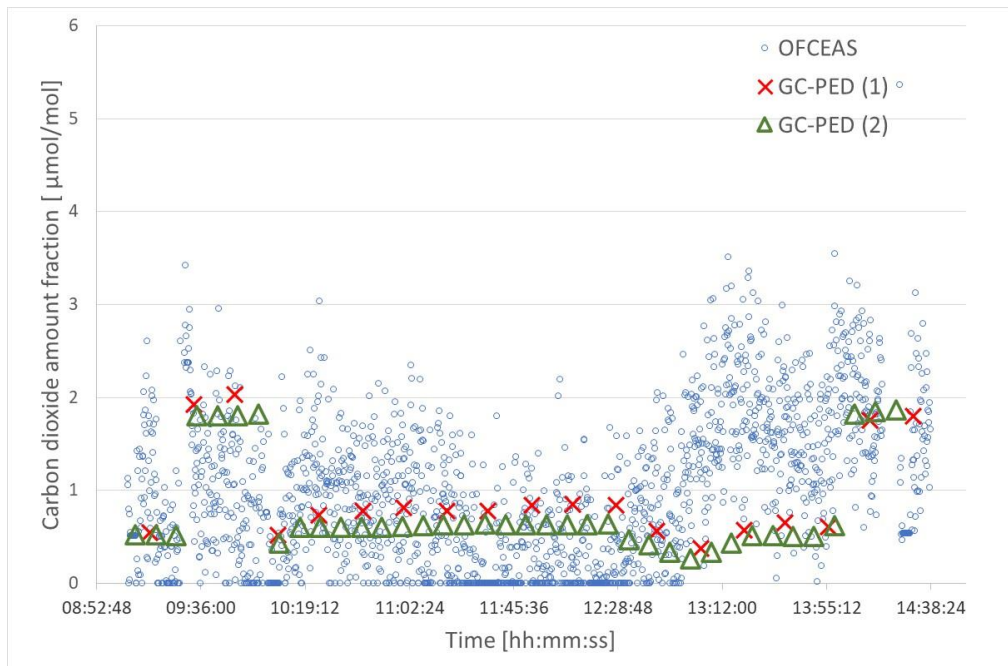

Figure 18. Comparison of direct techniques for the measurement of carbon dioxide online analysis at HRS. The two GC-PED (red cross and green triangle) techniques have lower limit of detection than OFCEAS (blue circle).

A good practice would be to estimate a reasonable limit of detection when the online analyser is installed and decide with the manufacturer on the software maximum and minimum response level (if above or below the software will report a specific message). It would be important to provide guidance to the operator on the amount fractions that are reliable to avoid misinterpretation or decision made on the edge of the instrument performance.

Response time of water content sensors

Figure 17 shows water content measurements using metal oxide and fibre optic principle hygrometers measuring water content at the HRS buffer storage system pressure alongside values measured by an NPL owned Tiger Optics CRDS instrument (Instrument A). Corrections to the measured values were made from calibrations of instruments F, G and H against the NPL Multi-gas, multi-pressure primary standard humidity generator prior to their measurements of the HRS hydrogen quality.

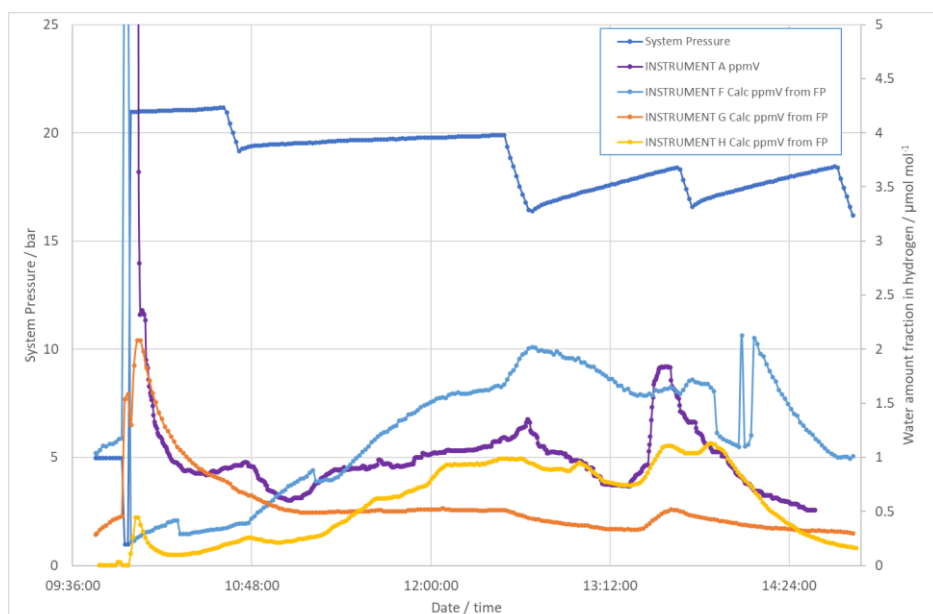

Figure 19. Water content measurements from metal oxide and fibre optic principles hygrometers measuring water content at HRS buffer storage system pressure alongside Tiger Optics CRDS instrument (Instrument A).

The response time to step changes of humidity of instruments F, G and H was also tested using a facility developed in the EMPIR Metrology for Advanced Hydrogen Storage Solution project (Funding reference: 19ENG01, website: www.mefhysto.eu) and it was found that instrument F had the slowest response time of the instruments tested. The event at the HRS that occurred around 13:30 causing a rise in the water content value was detected fastest by the CRDS spectrometer (Instrument A) and did not cause a rise in the measured value of instrument F until around 30 minutes after it had first been detected by the fastest recording instrument. This fact shows the importance of choosing an online instrument with a fast enough response time to allow appropriate reactive measures to be taken if the measurements are to be used for process control to ensure hydrogen fuel quality standards are met.

Readiness of sensors

The growth of hydrogen sector has led to the promotion of new sensors for the measurement of various compounds in hydrogen matrix. The water analysis sector is starting to have several sensors available as presented in this study. Novel sensors showed lack of validation or readiness. One ~~current~~ sensor tested was not suitable for use on receipt, electrical wiring to power was required to be done by the customer. Secondly, the sensor interface was not able to recognise the type of sensor without additional software able to identify which compounds are tested, therefore it was possible to mix up the systems. This may lead to potential issues when the sensors are moved for maintenance or to be used at various locations. Finally, the performance of the system during the test was not comparable to the data provided by the manufacturer. The sensor from Mirsense using Photoacoustic technology reported value more than 20 times above the expected value and a low sensitivity when exposed to water or CO₂. Despite being validated in nitrogen, this sensor lacked testing and validation in hydrogen matrix. Therefore, it is critical to assess the validation results of the sensor and realise a calibration and probably validation when implemented at the site.

It is clear from the MetroHyVe 2 experience that low-cost sensors lack validation procedure and facility for hydrogen gas. Early implementation may lead to low reliability of the data and issues in decision making by the operators or the end users. The metrology around sensor validation supporting the development of the sensor to a TRL level allowing use on real life system.

Impact and variation of hydrogen quality in function of events

The online analysis highlighted the importance of real time monitoring as it allowed the identification of rapid events as in the Figure 20.

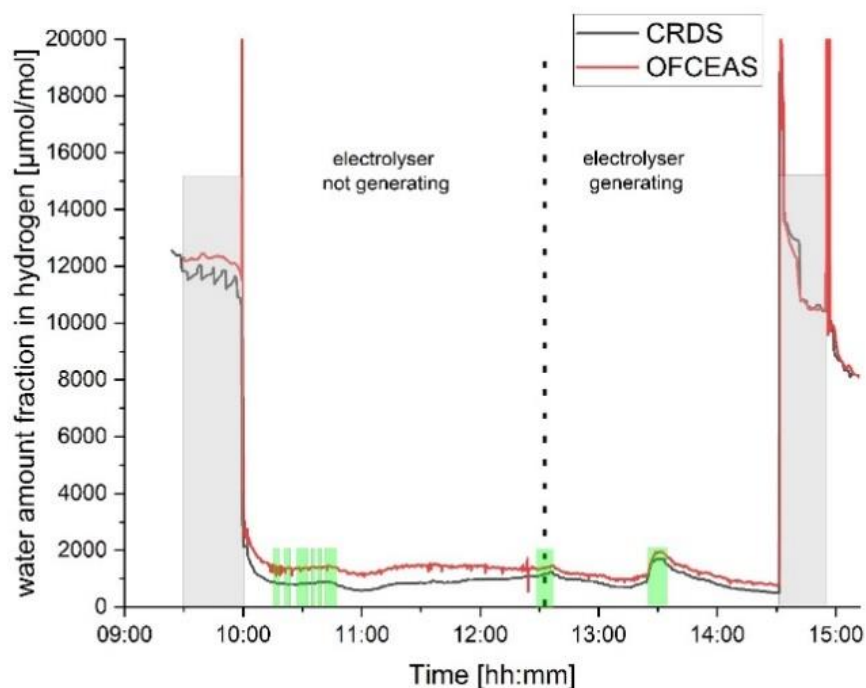

Figure 20. Evolution of water amount fraction over time and correlation with event at the hydrogen refuelling station (electrolyser status and refuelling event in green square area).

During the last refuelling event highlighted in green, an increase in water amount fraction was observed. Further investigation may be required to understand the reasons of the event or if it is reproducible. This observation would not have been captured by an offline analysis and further demonstrated the importance and the benefit of combining online analysis and offline analysis. Further studies and experiments will continue to provide more understanding on fuel quality evolution at HRS and the combined benefit of online and offline measurements.

summary of good practices and guidelines for online analysis at hydrogen refuelling stations

The studies highlighted the challenges associated with online analysis of gas compounds at hydrogen refuelling stations. The results confirmed some of the assumptions made in the probability of occurrence (Table 1). The studies realised by MetroHyVe 2 partners were instrumental in providing real examples of the challenges associated with online analysis but also the real benefit of it too. Following these experiences, some guidance is summarised below:

Good practices and guidelines prior to implementation

It is critical to consider several points before any implementation to ensure successful online analysis campaigns:

Selection of compounds to monitor:

- Importance of selecting suitable list of compounds. The report highlights that most of the compounds with highest probability of occurrence were identified. The selection of analyser is therefore simplified once a complete list is provided. Understanding and using methodology described in ISO 19880-8 and EN17124 is recommended.

Even if unexpected compounds were detected in case study 2, the results indicate that it was not during a short event, and it could have been captured by sampling and offsite analysis. To support such realisation, a sampling and analysis can provide additional data and guidance to support this selection.

- Clarify the intended level (range of analysis and limit of detection). Most analysers have clear working range. Ensuring good adjustment between instrument range and expected value is key to avoid unnecessary operational reactions (i.e., detection limit for CO₂ to close to ISO14687 or implication of reporting high nitrogen limit of detection to operator as detailed in case study 1).

Selection of the analytical system:

- ATEX analysers availability. Currently there is not many instruments available that are ATEX certified. While it is possible to implement a non ATEX analyser into an ATEX enclosure, it adds complexity to the operation and the system. When evaluating instrument ATEX rating, consider the whole installation including the wiring. As detailed in case study 1, some ATEX analysers suppliers may offer ATEX gas analysers but no ATEX wiring, which is not suitable for the uses in an ATEX zone. The implementation of non-ATEX analyser requires extra consideration to ensure the safe implementation of the system within the HRS.
- Instrument validation and performance. It is critical to ensure that analysers were validated for the range, limit of detection and condition of operations. Without such evidence, the instrument may not achieve the expectation of the end users. It is critical to ensure validation in hydrogen matrix, several analysers are untested in hydrogen and may not be suitable or require significant validation before being suitable.

A clear lack of guidance and facility in online analyser validation leads to end users' disappointment in real life experience (i.e., photoacoustic technology). Further study and development are required to support this aspect.

- Frequency of the analysis. The frequency of analysis will define the event that can be monitored by the instrument. To monitor a refuelling event of 5-10 min, an analyser has to perform analysis every minute or less to provide sufficient resolution to monitor any rapid changes.
- Instrument requirements. It is critical to consider all the utilities required to operate the analyser including power, compressed gas (i.e., carrier gas, compressed air). Instrument requirements may have implication in the selection of analysers.

Good practices and guidelines during implementation

- Location of analysers. It is critical to ensure that the analysers are located close to the sampling point and in a safe location based on its ATEX rating and site requirements. A consensus may need to be used for the distance to the sampling as safety will be the priority. In case study 3, the analysers were more than 15 meters from the sampling point to ensure the safety.
- Venting and new safety consideration related to analysers. The analysers will often have sample vented during operation. Any vent creates a new ATEX zone that needs to be considered with respect to site safety. A specific and safe vent area needs to be

implemented in relation to site requirement and local regulation. Moreover, utilities may bring additional risk related to pressurised gas or electricity. The location of pressurised cylinder for operating a gas chromatographer needs to be implemented in line with pressurised gas regulations. These additional risks have to be included on the overall site operation, risk assessment and hazard and operability (HAZOP) study. If calibration gases are implemented, it is recommended to use gas calibrants in hydrogen matrix. It would require the site to consider the safety related to use and operation of high-pressure flammable cylinders on site. It creates another area and risk that needs to be integrated in the overall site plan and safety study.

- Conditioning of the online analysis line. Before online analysis or after any maintenance or event on the online analysis line, inerting with nitrogen is required to avoid contact between air and hydrogen. The length of the online analysis line may require a sufficient time for purging. It is therefore recommended to ensure sufficient time to purge the line and then operate constant online analysis (24/7) or to introduce a fast-purging line process to the gas supplied to the analyser is not contaminated by the inert gas.

Good practices and guidelines for online analysis operations

- Importance of onsite validation or calibration. Based on the overall results, it is important to verify the accuracy of the instrument results using a calibration gas at the site. It would allow correction of the measurement based on the operating conditions that may differ from manufacturer recommendation based on site requirements. Secondly, it would help identify issue in the flow path to the analyser (i.e., small leak, response delay). During the three exercises in this report, calibration was realised onsite.
- Response time. It is important to realise that the analyser response may not represent the actual gas composition. The report highlights the difference in analyser response time. Despite being accurate, some analysers may have delay. The operational team should be aware of it to ensure that appropriate and timely actions are implemented.
- Understanding results and actions. It is important to inform the operation team of the boundaries of the online analyser (i.e., limit of detection versus visible value) and define reaction level based on the analyser ability to detect. As most analysers are reporting value in ppm, an operator may be misled by the value on the screen. Therefore, defining reaction level as value threshold when the analyser response is reliable or when to act in case of deviation above the ISO 14687 threshold is critical.

Acknowledgement

The authors would like to thank instrument manufacturers that supported this work (ASDevice, TigerOptics, Process Sensing, Durag group AP2E).

References

Metrological guidelines for the validation, calibration and quality control of online gas analysers and sensors performing analysis of hydrogen contaminants regulated in EN 17124:2018 and ISO 14687
MetroHyVe 2 - Grant agreement no: 19ENG04

-
- [1] ISO 14687:2019—Hydrogen Fuel Quality—Product Specification; International Organization for Standardization: Geneva, Switzerland, 2019.
 - [2] EN 17124:2022—Hydrogen Fuel—Product Specification and Quality Assurance—Proton Exchange Membrane (PEM) Fuel Cell Applications for Road Vehicles; European Committee for Standardization: Brussels, Belgium, 2022.
 - [3] Hydrogen Fuel Quality for Fuel Cell Vehicles J2719_202003; SAE International: Warrendale, PA, USA, 2020.
 - [4] Arrhenius, K.; Bacquart, T.; Schröter, K.; Carré, M.; Gozlan, B.; Beurey, C.; Blondeel, C. Detection of Contaminants in Hydrogen Fuel for Fuel Cell Electrical Vehicles with Sensors—Available Technology, Testing Protocols and Implementation Challenges. *Processes* 2022, 10, 20.
<https://doi.org/10.3390/pr10010020>
 - [5] ISO 19880-8:2019—Gaseous Hydrogen—Fuelling Stations—Part 8: Fuel Quality Control; International Organization for Standardization: Geneva, Switzerland, 2019.
 - [6] Bacquart, T.; Murugan, A.; Carré, M.; Gozlan, B.; Aupretre, F.; Haloua, F.; Aarhaug, A.T. Probability of occurrence of ISO 14687-2 contaminants in hydrogen: Principles and examples from steam methane reforming and electrolysis (water and chlor-alkali) production processes model. *Int. J. hydrogen Energy* 2018, 43, 11872–11883.
 - [7] Blondeel, C.; Lefebvre, M.; Bartlett, S.; Arrhenius, K.; A2.4.4: Guideline report for laboratory-based validation and quality control of sensors. 06/05/2022.
https://www.sintef.no/globalassets/projectweb/metrohyve-2/metrohyve-2---a2.4.4_-guideline-report-for-laboratory-based-validation-and-quality-control-of-sensors---final-rev---07.06.2022.docx-1.pdf
(accessed on 23/10/2023)



REPORT:

A2.5.2: Preliminary assessment of the safety of installing sensors and online analysers at hydrogen refuelling stations.

Authors: Jamie Malkinson, Ashley Brown, Karin Schröter, Claire Blondeel Dimopoulos, Panayotis, Thomas Bacquart

Confidentiality: Public

Submission date: 08.12.2022

Revision: -

<https://www.sintef.no/projectweb/metrohyve-2/>

Report A2.5.2: Preliminary assessment of the safety of installing sensors and online analysers at hydrogen refuelling stations.	
Funding European Metrology Program for Innovation and Research	Grant agreement no: 19ENG04
Project name Metrology for Hydrogen Vehicles 2	Project short name MetroHyVe 2
Author(s) Jamie Malkinson ITM Power Ashley Brown ITM Power Karin Schröter EMPA Claire Blondeel Air Liquide Thomas Bacquart NPL	Pages 17 pages
<p>Summary</p> <p>The report is proposing an example of risk assessment of installing sensors and online analysers at hydrogen refuelling stations. It is an initial guidance to address some of the critical risks. This report will be revised after the online analysis campaign with experience feedback from MetroHyVe 2 partners.</p> <p>This report was written as part of activity 2.5.2 from the EMPIR Metrology for Hydrogen Vehicles 2 (MetroHyVe2) project. The three-year European project commenced on 1st August 2020 and focused on providing solutions to four measurement challenges faced by the hydrogen industry (flow metering, quality assurance, quality control, sampling and fuel cell stack testing). For more details about this project please visit https://www.sintef.no/projectweb/metrohyve-2/.</p>	
Confidentiality	Public

This project “Metrology for Hydrogen Vehicles 2” (MetroHyVe 2) has received funding from the EMPIR programme co-financed by the Participating States and from the European Union’s Horizon 2020 research and innovation programme under Grant agreement No [19ENG04].

EMPIR



The EMPIR initiative is co-funded by the European Union's Horizon 2020 research and innovation programme and the EMPIR Participating States

Contents

Introduction	4
Implementation of online analysis.....	4
Location of online analysis.....	4
Instrumentation and online analyser available	5
Case study 1: Sensor implementation at HRS in ATEX zone for long term monitoring.....	7
Hydrogen refuelling station specification.....	7
Analytical section implementation	7
Results of the online analysis campaign	9
Case study 2: Sensor implementation at HRS at nozzle (modified feed) for long term monitoring	10
Hydrogen refuelling station specification.....	10
The Empa setup for the measurements	11
Analytical section implementation	13
GC-IMS and MicroGC (Outdoor-capable measuring cabinet).....	13
Fourier Transform Infra-Red (FTIR).....	13
Cavity ring down spectrometer (CRDS).....	14
Results of the online analysis campaign	14
Investigation of unexpected contamination or events.....	14
Evolution of nitrogen over time.....	16
Evolution of water amount fraction over time (ambient temperature)	16
Consecutive measurement – transition between sampling campaign.....	18
Impact	18
Case study 3: Sensor implementation at HRS at storage location outside ATEX zone.....	19
Hydrogen refuelling station specification.....	19
Analytical section implementation	20
Safety, ATEX zoning and implementation at HRS	20
Instrument description	21
Results of the online analysis campaign	22
Comparison of analysers and calibration.....	22
Distance between online analyser and system.....	24
Importance of analysis frequency.....	25
Limit of detection and data interpretation	26
Response time of water content sensors	27
Readiness of sensors.....	28
Impact and variation of hydrogen quality in function of events	28
summary of good practices and guidelines for online analysis at hydrogen refuelling stations.....	29
Good practices and guidelines prior to implementation.....	29
Metrological guidelines for the validation, calibration and quality control of online gas analysers and sensors performing analysis of hydrogen contaminants regulated in EN 17124:2018 and ISO 14687	

Good practices and guidelines during implementation.....	30
Good practices and guidelines for online analysis operations	31
Acknowledgement	31
References	31
Annex A – Example of risk assessment	33
Introduction	38
Risk assessment example:	39

Introduction

The implementation of online analyser at hydrogen refuelling stations is critical to monitor the quality of the fuel in real time however it comes with complexity in term of implementation and safety.

The report investigates some safety aspect around the installation of online analysers and sensors at hydrogen refuelling stations. Several points are presented below to identify and tackle some of the critical risks added by the presence/addition of online analyser:







- risk of leak from the hydrogen refuelling station (new connection to the instrument)
- instrument compliance with the ATEX regulation and ATEX zoning of the hydrogen refuelling station (i.e., if the instrument is non-ATEX, it should be out of the ATEX zone, risk should be considered based on the instrument location and venting).
- risk around the venting requirement for the analysis or from the online analyser (i.e., the instrument require an additional vent that needs to be added into the ATEX zone and made compliant with the site requirement)
- most analysers operate at low pressure (< 5 bar gauge), therefore there is a risk of over-pressurisation of sampling / analysis equipment and this risk needs to be mitigated prior to any operation considering pressure relief valve and subsequent risk analysis
- the installation of the online analyser in a protected room or box or outside can bring additional risk regarding the use of electrical equipment outside (including unmanned operation for an overnight N2 purging process (16hrs)) or the risk associated with gas analyser in a small, closed environment (i.e., asphyxiation, flammable atmosphere which will require sensor and adequate venting)
- several online analysers for hydrogen fuel quality are non ATEX rated in 2022, therefore there is additional electrical risk especially bad weather condition
- the presence of external worker to implement, monitor, calibrate or perform maintenance on online analyser at the HRS is an additional risk to consider especially when access to hydrogen compound is required
- the implementation, monitoring, calibration or performing maintenance on online analyser requires manual handling and/or moving heavy equipment or cylinders. This is an additional risk to consider especially when working in compounds with limited support.

The report is proposing an example of risk assessment considering most of the points above as an initial guidance to address some of the critical risks. This report will be revised after the online analysis campaign with experience feedback from MetroHyVe 2 partners.

Risk assessment example:

The document needs to have clear history including date of issue, reference, revision and author, checker and authoriser. The scope of work should be clearly defined (for example: “This risk assessment covers general risks associated with hydrogen sampling for the purpose of checking quality via a gas analyser or sensor at a hydrogen refuelling station. This risk assessment does not cover quality sampling at the refuelling nozzle, only from the Electrolyser or from the buffer tank.”)

The list of PPE required should be clearly specified as in the example below:

PPE REQUIREMENTS:			
Safety Glasses/Goggles 	Gloves 	Safety Boots 	High Visibility Clothing 
Personal gas detector required 	Static protection 		

Summary of Risk Matrix:	
FREQUENCY (F):	PERSONNEL INVOLVED (P):
1 - Very Infrequent (Yearly)	1 - 2-4 Persons
2 - Infrequent (Monthly)	2 - 4-8 Persons
3 - Frequent (Weekly)	3 - 8-15 Persons
4 - Very Frequent (Daily)	4 - 15+ Persons or Lone Worker
LIKELIHOOD (L):	CONSEQUENCE (C):
1 - Very unlikely	1 - Minor / No Injury
2 - Unlikely	2 - Minor Injury Resulting in First Aid
3 - Fairly Likely	3 - Injury Resulting in 1-3 days Absence
4 - Likely	4 - Injury Resulting in a 3-6 days Absence
5 - Very Likely	5 - Potential RIDDOR / 7 days + absence
6 - Imminent	6 - Potential Fatality / Death
RESIDUAL RISK (RR): Frequency + Likelihood x Consequence + Personnel = risk rating out of 100	

Risk Assessment:

Consequence & Personnel	10	20	30	40	50	60	70	80	90	100
	9	18	27	36	45	54	63	72	81	90
	8	16	24	32	40	48	56	64	72	80
	7	14	21	28	35	42	49	56	63	70
	6	12	18	24	30	36	42	48	54	60
	5	10	15	20	25	30	35	40	45	50
	4	8	12	16	20	24	28	32	36	40
	3	6	9	12	15	18	21	24	27	30
	2	4	6	8	10	12	14	16	18	20
	1	2	3	4	5	6	7	8	9	10
Likelihood & Frequency										

SUMMARY:

- The Risk Assessment is a task-based assessment of Health, Safety & Environmental factors.
- **FREQUENCY (F):** How often is the task performed
- **LIKELIHOOD (L):** Likelihood of an incident occurring
- **CONSEQUENCE (C):** Consequence/ Severity of the hazard or incident
- **PERSONNEL INVOLVED (P):** The number of people involved in the task

Activity	Associated Risk & Hazard	At Risk	Current Controls	F	L	C	P	RR	Possible Further Actions	F	L	C	P	RR	Comment
Hydrogen leak from plant gas handling room equipment / pipework, to form potentially explosive atmosphere	Ignition causing fire or explosion	Sampling operative / passers-by	<p>Prevention / minimisation of leak</p> <ul style="list-style-type: none"> • Electrolyser carries out automated leak check, up to outlet valve, upon start-up or on regular time based on the operators process. • Manual leak checks as part of routine inspection by maintenance staff when test is set up • Before commencing work, carry out an inspection of the gas handling room, including a check with an (ATEX rated) hydrogen sensor <p>Prevention of ignition</p> <ul style="list-style-type: none"> • Define where the new hazardous areas will be as a result of the work, and ensure that there are no potential ignition sources in these areas (first step) • Ensure the ATEX area has been clearly defined and applied (i.e., Area around gas handling room is Zone 2) (depending on explosion risk assessment) 	1	1	6	2	16							

			<ul style="list-style-type: none"> ● Infra-red sensor or flame detector covering the gas handling room, to activate the fire alarm and warn staff, and notify the monitoring company, who in turn can notify the fire brigade 												
Hydrogen leak from sampling equipment / pipework, to form potentially explosive atmosphere	Ignition causing fire or explosion	Sampling operative / passers-by	<p>Prevention / minimisation of leaks</p> <ul style="list-style-type: none"> ● Manual/procedure leak check by maintenance staff of all pressurised equipment after test set up ● Supply of hydrogen to the sampling equipment have to be stopped if needed by closing the manual valve or gas shut-off system ● Any ignition sources associated with the sampling / analysis equipment are located outside of the existing hazardous areas on site . Equipment could be inside if their ATEX certification is in coherence with the ATEX Zone ● Definition of where new hazardous areas will be created as a result of the work, and ensuring that there are no potential ignition sources in these areas <p>Prevention of ignition As above</p> <p>Protection of personnel As above</p> <ul style="list-style-type: none"> ● Additional e-stop button close to the sampling location/analyser system (1-2 meters distance) 	1	1	6	2	16							
Vented hydrogen from purging /	Ignition causing fire or explosion	Sampling operative	<p>Prevention of ignition</p> <ul style="list-style-type: none"> ● Area around vent from sampling equipment to be treated as Zone 0, with no potential ignition 	1	1	6	2	16							

depressurisation etc		/ passers-by	<p>sources in the hazardous area, otherwise with appropriate electrical equipment used. Vent exit will be routed to gas panel vent and leak checked at both ends before use</p> <ul style="list-style-type: none"> Outdoor venting ensures adequate ventilation <p>Protection of personnel</p> <ul style="list-style-type: none"> Staff to carry (ATEX rated) portable hydrogen sensors to indicate if a potentially explosive atmosphere is present 												
Over-pressurisation of sampling / analysis equipment	Ignition causing fire or explosion	Sampling operative / passers-by	<p>Prevention of over pressure</p> <ul style="list-style-type: none"> Pressure control valve to be used in gas panel before equipment to ensure only the correct pressure is going to the equipment. Adapt the pressure of the safety valve according to the working pressure of the equipment and the sampling element Electrolyser will halt generation at a pressure below the maximum allowed pressure level of the tanks and of the instruments lines (including pressure regulator and specific PRVs) Phrasing: The electrolyser system is protected by pressure relief valves (PRVs) set the maximum allowed pressure level of the tanks and instruments The analyser is protected by pressure regulator and PRVs to avoid any pressure above maximum allowed pressure in the system. Pressure monitoring using sensors on the sampling/equipment line will allow quick reaction in case of all pressure regulation and PRVs failure. 	1	1	6	2	16							

			<p>Stop valve is present before the analyser to stop overpressure reaching the instrument.</p> <p>Protection of personnel</p> <ul style="list-style-type: none"> Wear portable ATEX rated hydrogen sensor throughout sampling 												
Use of electrical equipment outside - including unmanned operation for an overnight N2 purging process (16hrs)	Ignition causing fire or explosion	Sampling operative / passers-by	<p>Prevention of ignition</p> <ul style="list-style-type: none"> IP54 extension leads in place Manned operation when sampling will be with gazebo over equipment Unmanned nitrogen purge will take place inside store room. No weather worries. The room need to be vented or have air depletion alarms RCD in use at all times <p>Protection of personnel</p> <ul style="list-style-type: none"> Wear portable ATEX rated hydrogen sensors throughout sampling. 	1	1	1	6	14							
Nitrogen purging inside	Nitrogen build up causing respiratory health problems	All in vicinity	<p>Prevention of build up</p> <ul style="list-style-type: none"> Nitrogen source will be outside. Electrical equipment will be inside, venting the purge gas back outside the door or connected to the vent Leak test have to be done when the equipment are installed <p>Protection of personnel</p> <ul style="list-style-type: none"> When the room is revisited, an O2 depletion sensor will be used before entering the room depending on the potential leak 	1	1	1	6	14							

<p>Non ATEX rated electrical equipment in bad weather during H2 sampling</p>	<p>Ignition causing fire or explosion</p>	<p>All in vicinity</p>	<p>Prevention of ignition</p> <ul style="list-style-type: none"> • Sampling equipment is never left unmanned while outside. It needs to be clearly labelled to not be touched by untrained persons and secured against operation through untrained persons • In the event of rain, the test will be stopped and all electrical systems turned off • Gazebo in place to reduce risk. If rain does come, we can turn off equipment before rain affects equipment <p>If the electrical equipment is not available for being outside (IP54 rating), it has to be protected and not impacted by the weather. After the rain, the equipment could not be dried.</p> <p>Protection of personnel</p> <ul style="list-style-type: none"> • Wear portable ATEX rated hydrogen sensor throughout sampling 	<p>1</p>	<p>1</p>	<p>1</p>	<p>6</p>	<p>14</p>									
<p>Working in a hydrogen compound</p>	<p>Slips, trips and falls. Working within a hazardous zone</p> <p>Large amounts of stored hydrogen gas</p>	<p>All in vicinity</p>	<p>Prevention of slips etc</p> <ul style="list-style-type: none"> • POWRA completed before beginning the task • Keep work area tidy (: Handguards, Marked obstacles Hot/Cold surfaces marking against burns), clean as you go <p>Protection of personnel</p> <ul style="list-style-type: none"> • Appropriate PPE as page 2 	<p>1</p>	<p>1</p>	<p>6</p>	<p>1</p>	<p>14</p>									
<p>Manual handling moving heavy equipment or cylinders</p>	<p>Back injury, strains sprains, crushed limbs, burns</p>	<p>Sampling operative</p>	<p>Prevention of injury</p> <ul style="list-style-type: none"> • POWRA completed before beginning the task 														

			<ul style="list-style-type: none"> • Staff have training on manual handling • Cylinder trolley in use • Cylinders have to be attached on site • Cylinder shall be securely attached on a solid point (i.e., strapped on a pillar, cylinder trolley, infrastructure) <p>Protection of personnel</p> <ul style="list-style-type: none"> • Safety boots to be worn • And static protection if we are in an ATEX zone • ATEX working clothes, portable alarms for explosivity limit, safety goggles, safety boots (antistatic and toe cap protection), ATEX gloves 	1	2	1	5	18							
--	--	--	--	---	---	---	---	----	--	--	--	--	--	--	--

Ensure the overall risk rating is recorded with review period and date. If actions are required, a log of the actions, owner, dues date and completion date needs to be present. Finally the risk assessment needs to be signed off

Overall Risk Rating			
Please indicate the final risk rating below. As a guide, this is based upon the highest RR entered into the assessment with the current controls in place. The owner of this assessment or HSE may increase the RR from this level at their discretion, but it should not be decreased without additional controls.			
Risk Rating	Please Select	Review Period	Next Review Date
Low Risk: No further action, but ensure controls are maintained	<input checked="" type="checkbox"/>	Triennial Review	
Medium Risk: Further controls should be considered before next review	<input type="checkbox"/>	Biennial Review	Enter date
High Risk: Further controls should be implemented before next review	<input type="checkbox"/>	Annual Review	Enter date

Actions

Metrological guidelines for the validation, calibration and quality control of online gas analysers and sensors performing analysis of hydrogen contaminants regulated in EN 17124:2018 and ISO 14687
MetroHyVe 2 - Grant agreement no: 19ENG04

The person creating this assessment is responsible for allocating the actions and dictating the action owner and due date.
 Once the assessment has been reviewed by HSE, each action is added to the HSE Action Tracker and closed out on there once complete.

Action	Action Owner	Due Date	Completion Date

Sign Off

By signing below, you are agreeing that you have read and understood the Risk Assessment, including all the highlighted hazards and risks involved along with the devised control measures. These control measures must be applied and followed at all times. If any deviations are made, works must be stopped and a Point-of-Work Risk Assessment (POWRA) completed, in line with any advice from HSE as appropriate.

Name	Signature	Job Title	Date
			Enter date
			Enter date